

Computational Investigation of a Wind Turbine Shrouded With a Circular Ring

 Open
Access

 Mohamed Takey¹, Tholudin Mat Lazim¹, Iskandar Shah Ishak^{1,*}, N.A.R Nik Mohd¹, Norazila Othman¹
¹ School of Mechanical Engineering, Faculty of Engineering, Universiti Teknologi Malaysia, 81310 Skudai, Johor, Malaysia

ARTICLE INFO

Article history:

Received 22 August 2020
 Received in revised form 21 October 2020
 Accepted 24 October 2020
 Available online 30 October 2020

ABSTRACT

Apparently a wind turbine shrouded with a diffuser could produce more power than the bare one. In the recent development, shrouded turbines often have a circular vertical flange attached to its rear edge. In this research work, a new design concept for shrouded turbines is introduced using a circular flange ring instead of a diffuser. The performance of a wind turbine shrouded with the conventional configuration of flanged diffusers is firstly investigated. This allows comparison to be made with the performance of the new design proposed in this project. The bare turbine used in this research work is a horizontal axis wind turbine with a diameter of 0.6 m, and the flange height is 10% of the diameter. The performance of the shrouded turbine is investigated using computational fluid dynamics; by solving the flow field using three-dimensional Reynolds Averaged Navier-Stokes for incompressible flow. Findings indicate that the performance of the turbine shrouded with the flange ring is superior to the bare turbine by 33%. It also has benefits over the conventional design as this new design concept is simpler and uses lesser material since it is not using the diffuser, which favorably, in turn, will reduce the cost. Subsequently, the findings of this research may have the potential to expedite the developments of green-source energy that undoubtedly could benefit the entire growing wind turbine industry.

Keywords:

Wind lens; wind turbine aerodynamics;
 flanged diffuser; DAWT

Copyright © 2020 PENERBIT AKADEMIA BARU - All rights reserved

1. Introduction

Countries close to the equator are characterized by low wind speeds [1-3]. Since wind power is proportional to the cube of wind speed [4], these countries might have limited wind energy potentials.

Shrouded wind turbines had been proven to have an enhanced performance at low wind speeds [5]. The shrouds' design evolved from a long length diffuser to a short diffuser with a flange attached at its rear. The flange contribution to performance is dominant, and hence it would be interesting to investigate the case where the shroud consists of a flange only without a diffuser.

* Corresponding author

E-mail address: shah@utm.my (Iskandar Shah Ishak)

<https://doi.org/10.37934/cfdl.12.10.4051>

The main objective of this research work is to quantify the turbine torque output when a thin flange shrouds it without a diffuser. To accomplish this, CFD was used to analyze the three following configurations:

- i. A wind turbine shrouded with a flanged diffuser
- ii. A wind turbine shrouded by a diffuser only
- iii. A wind turbine shrouded by a flange only

The torque output of the three configurations is also compared to the bare turbine configuration. Figure 1 illustrates the road map of the research work.

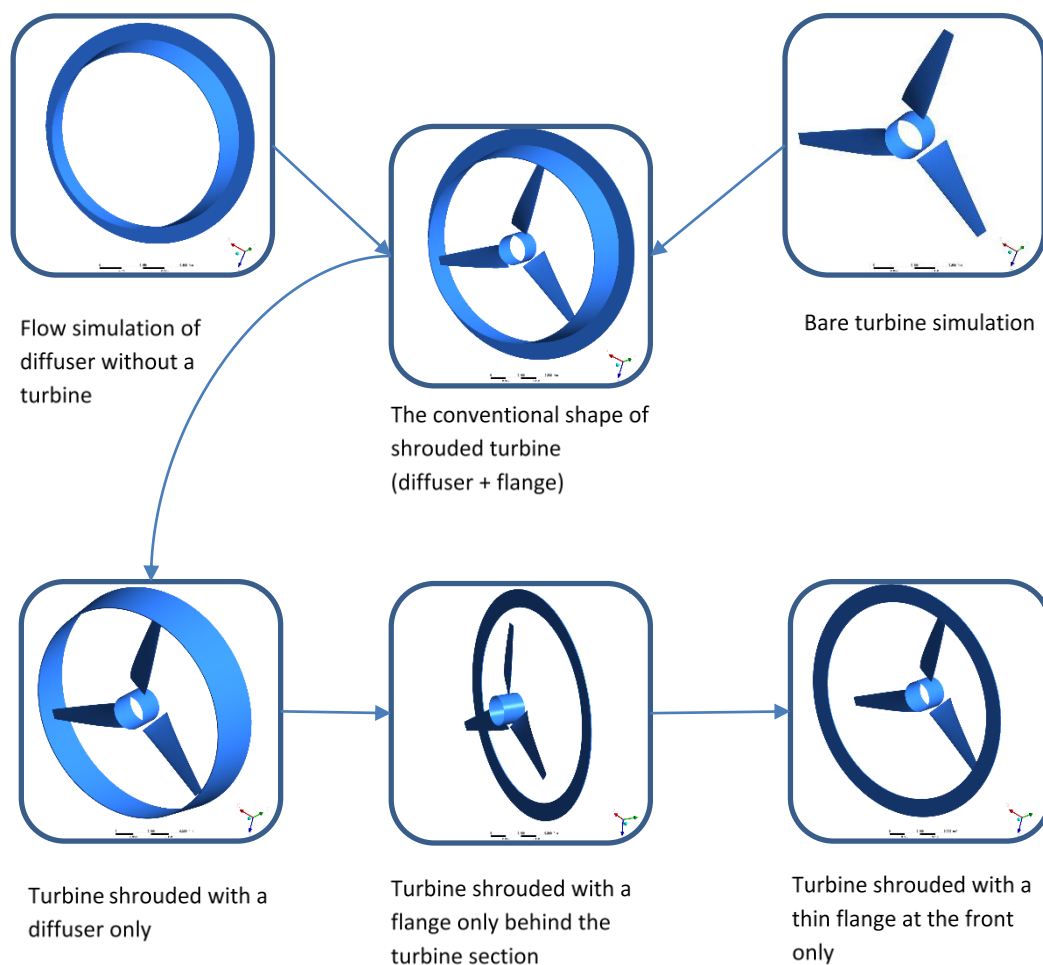

Fig. 1. Roadmap of the research work

1.1 A Brief Review of Shrouded Turbines

Variable area ducts; nozzles, or diffusers have been known to change the speed of a given flow passing through them because of the continuity equation Eq. (1)., hence for any steady, subsonic, and incompressible flow, narrowing the area of a hollow duct at a certain section will increase its speed [6].

$$d(\rho uA) = 0 \rightarrow \rho uA = \text{constant} \quad (1)$$

where; ρ is the flow density, u is the velocity of the flow, and A is the cross-sectional area.

A group of researchers in Japan has shown by wind tunnel testing that a diffuser placed in a free flow will accelerate the airspeed [7,8]. The diffuser configuration creates a pressure difference across its length such that the inlet will have a sub-atmospheric pressure, which encourages upstream air to flow through the diffuser.

Many researchers have proved that mating a turbine with a diffuser increases the power significantly in a way that it may exceed the Betz limit, which is 59.3% [5,9], wind turbines shrouded with a diffuser are known as diffuser augmented wind turbine (DAWT) or wind lens [10].

For a subsonic flow, two main parameters influence the flow behavior inside a diffuser: Firstly, the area ratio between the exit and the throat, and secondly, the back pressure at the diffuser rear [6].

For a fully attached flow inside the diffuser, increasing the area ratio between the exit section and the throat; accelerates the flow at the diffuser's inlet. This fact had inspired the pioneer designers of DAWT to make diffusers with large, inclined angles; some designs had an opening angle up to 60°. However, to overcome the adverse pressure gradient that occurs inside the diffuser walls and causes flow separation, they needed to use boundary layer control methods such as air slots or multistage diffusers, which added complexity to their designs [11-14].

None of these designs were upgraded to a commercial phase, until a group of researchers at Kyushu University in Japan started investigating a different design concept of shrouded turbines intensively, numerically, and experimentally, and they called it the wind-lens. They proposed several designs of wind lens since 2004, which are all characterized by having a very compact diffuser length, limited opening angle, and a high flange at its rear. The flange acts as a vortex generator; it produces a low-pressure zone at the back of the diffuser, which helps accelerate the flow. Wind-lens designs have been proven practical and efficient, but with the price of a total drag increase [8,10,15-17].

Many other researchers have further investigated the concept of the wind lens or flanged diffusers such as, Aranake *et al.*, [5], who used low Re airfoils as a diffuser cross-section, Lipian *et al.*, [18], who tested the concept of twin-rotor shrouded by a diffuser, Göltenbott *et al.*, [19] who tested the concept of grid configuration of series of single rotor wind lens system, Liu *et al.*, [20] who tried to reduce the drag of the wind lens by optimizing the wind lens profile using genetic algorithm, and also Abdelwaly *et al.*, [21] who had applied the wind lens concept to NREL Phase VI turbine and showed 106% increase in torque. Few prototypes were also successfully built in Japan and China [16].

This research will adopt the idea of the compact shrouded turbine, which relies mainly on the flange part; however, we would like to investigate what would be the performance of the system if the diffuser is eliminated.

2. Model Description

The shrouded turbine system consists of two main parts, the first part is a horizontal axis wind turbine, and the second part is a cylindrical diffuser that surrounds the turbine.

2.1 Turbine Description

The wind turbine which is used in this study is a three-bladed horizontal axis wind turbine that has a diameter 0.6 m as shown in Figure 2a; the cross-section of the turbine blade, as shown in Figure 2b, is the thin airfoil SD2030, which is suitable choice for low Reynolds flow applications [22].

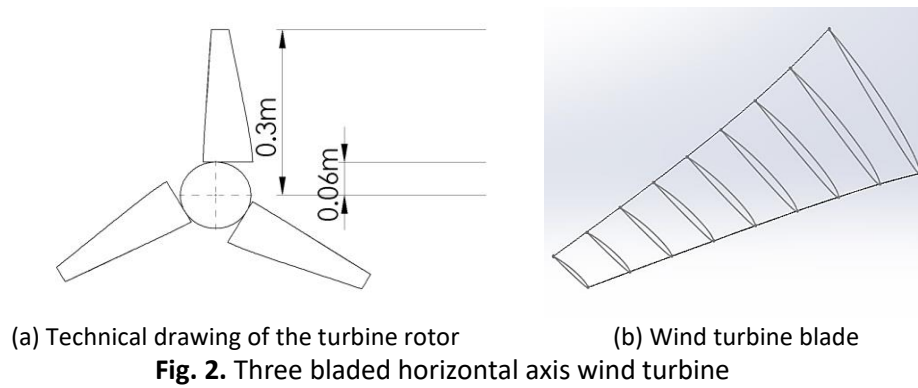

2.2 Diffuser Description

The diffuser configuration to be studied in this research is following the same concept that is adopted by Ohya *et al.*, [16], which is a diffuser with a short length (L), extended flange height (H), and length to diameter ratio less than 0.3, as shown in Figure 3; the diffuser's dimensions are listed in Table 1. The new configuration to be further studied, which just consists of a circular ring flange without a diffuser, has the same dimension of the flange reported in Table 1, where $H/D = 0.1$.

Table 1

Diffuser geometrical description

Inlet diameter (D)	0.6 m
Diffuser length (L)	0.14 m
Flange height (H)	0.06 m
Opening angle	10°

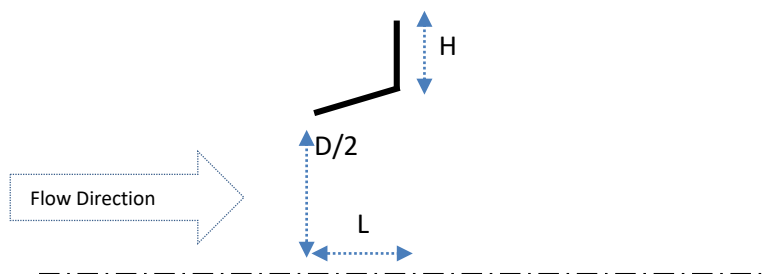

Fig. 3. A schematic diagram of the wind lens

3. CFD Simulation

The performance of both the bare turbine as well as the shrouded turbine has been investigated using 3D CFD simulation by solving the Reynolds averaged Navier-Stokes equations for incompressible flow, using CFX Ansys software. The Turbulence model used in this work is Shear stress transport. The upstream Inlet air velocity is fixed to 5 m/s throughout this work, while the rotational speed of the rotor varies between 200 to 1100 rpm with step 100 rpm, which corresponds to tip Reynolds number (Re) that ranges between 30000 to 45000. The Reynolds number of the diffuser is 2.1×10^5 as calculated using Eq. (2). A rotational periodic boundary condition is used in the simulation so that only one-third of the domain is solved to save computational time; other boundary conditions are shown in Figure 4a.

$$Re_{diffuser} = uD/\nu = 2.1 \times 10^5 \quad (2)$$

where D , is the diffuser inlet diameter, u in the upstream velocity, and ν is the kinematic velocity.

3.1 Computational Domain Description

The computational domain is 20 m long, which more than 33 times the diameter of the rotor; as shown in Figure 4a, it has been divided into two zones, a rotational domain that includes the turbine blade and a stationary zone that includes the diffuser wall. A C-grid zone with hexahedral structured mesh elements has been created along the blade span from root to tip as shown in Figure 4b to capture the flow inside the boundary layer inside the rotational domain; the height of the first layer close the wall surface was chosen small enough to make sure the dimensionless distance from the wall (Y^+) is less than 1. A zone of dense mesh elements is created around the diffuser to capture the pressure gradient that occurs across it. Figure 4c shows inflation layers, which were also created around the diffuser walls to capture the boundary layer. The mesh elements everywhere else in the domain are unstructured 3D tetrahedral cells, created using Ansys meshing.

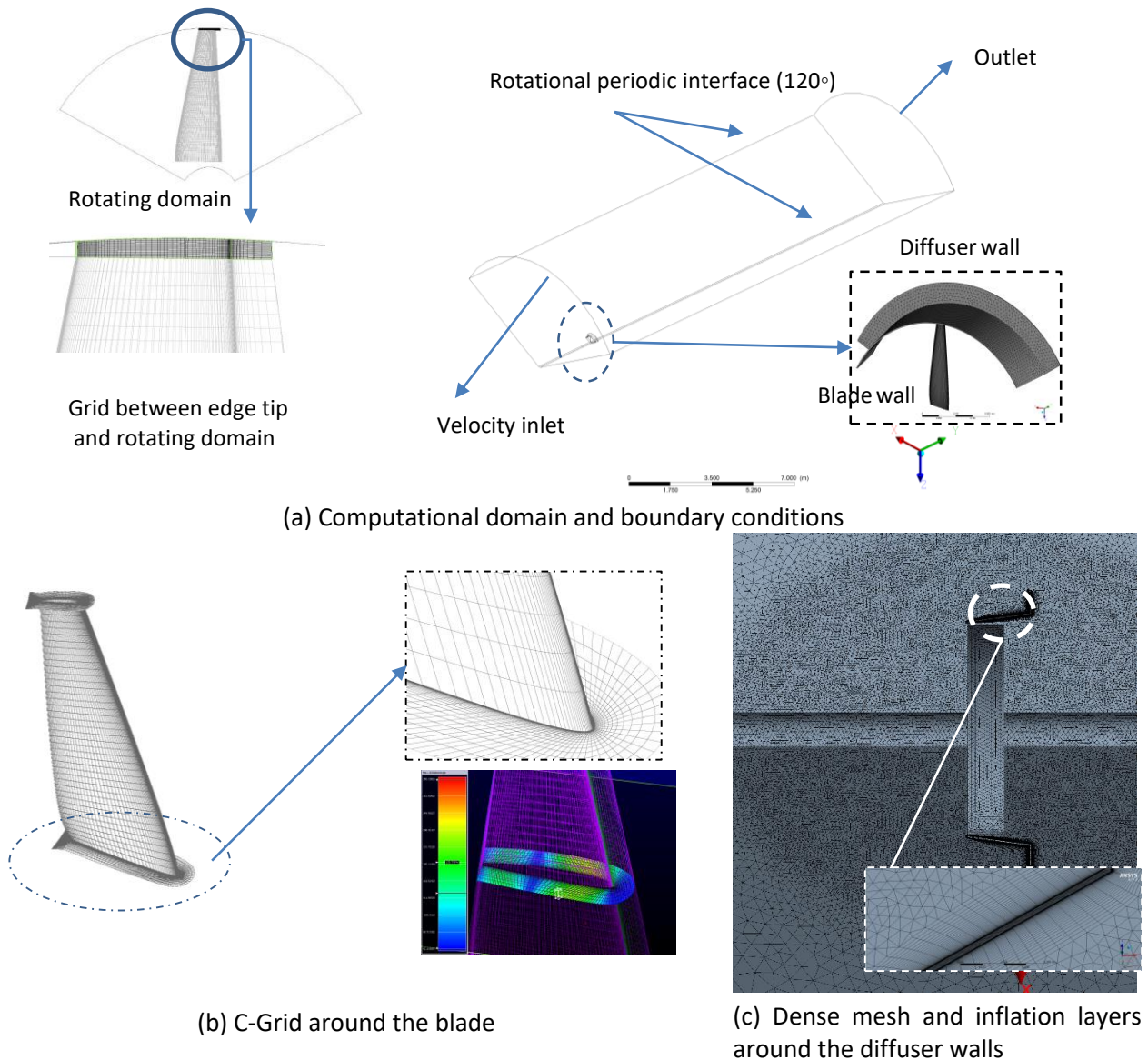

Fig. 4. Computational grid for the shrouded turbine

3.2 Grid Independence

Grid independence study has been carried out by changing the height of the first grid layer adjacent to the diffuser wall. The first grid height is $6e-5$ m. Table 2 shows that the value of the accelerated speed at the inlet of the diffuser changed only 0.0376 % after reducing the first layer element height to $6e-6$.

Table 2
Speed value at the diffuser inlet vs. first mesh element size adjacent to the diffuser

First Layer Value	Yplus Expected	Speed at inlet diffuser(m/s)
6.00E-06	0.1	5.3212
1.20E-05	0.2	5.3236
6.00E-05	1	5.3186
1.20E-04	2	5.3196
3.00E-04	5	5.3149

Similarly, the first layer in the C shape grid which surrounds the blade has been changed to make sure the grid is fine enough. Table 3 shows that the torque of the bare turbine changes only 0.28% when the first layer changed from $5e-6$ to $2e-6$.

Table 3
Torque value of the bare turbine vs. first mesh element size adjacent to the diffuser

First Layer Value	Y plus Expected	Torque/3 (N.m)
2e-6	0.05	0.0354
5e-6	0.1	0.0355
5e-5	1	0.0366
1e-4	2	0.0375
3e-04	6	0.0384
5e-4	8	0.0385

Similarly, the domain used in the simulation is 20m; the solution sensitivity to the length of the domain has been tested by changing the domain length to 5m,10m,15m, and 25m. The torque value of the shrouded turbine changed only by 0.14% when the domain length extended to 25m instead of 20 m.

The number of Inflation layers used around the diffuser is 40 layers; the sensitivity of the number of layers has been investigated by reducing the number of layers to 30,20 and 10 layers while keeping the first layer size $5e-6$ as fixed. The results have changed only 0.1% after reducing the layers to 30; however, the results have changed 3% after reducing the layers to 10 and 1.4% after reducing the layers to 20; hence it is concluded that 30 layers are enough to capture the flow in the boundary layer.

3.3 Validation

For validation purposes, the velocity at the diffuser center-line across its length resulted from this CFD model, and wind tunnel [7] are compared. It is found that the two results are agreeable with each other, thus validating this simulation work

The performance of the bare wind turbine using CFD (using steady-state moving reference frame simulation) is also compared with results from Qblade software, which uses Blade Element

Momentum Theory [23], to verify that the CFD results are in reasonable values. Figure 5 shows the Torque-RPM curve of the turbine using CFD vs. Qblade.

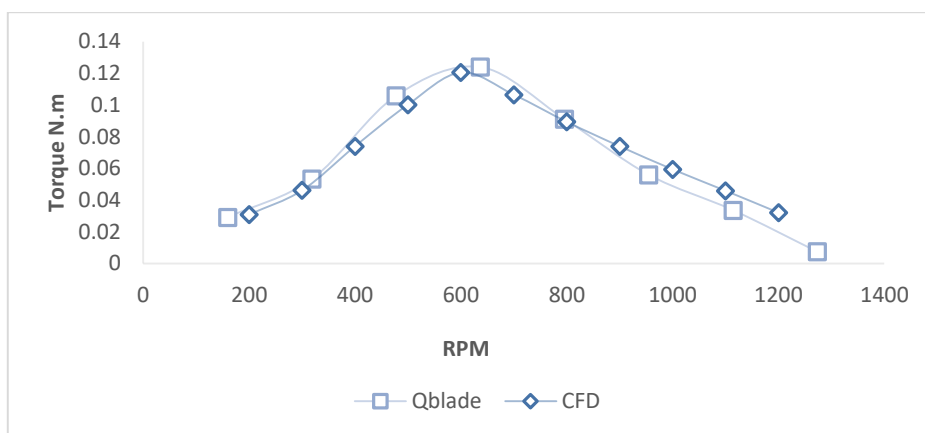

Fig. 5. Bare turbine performance at upstream speed 5 m/s

4. Results and Discussions

4.1 Performance of Diffuser Alone

The upstream velocity approaches the hollow diffuser, which was illustrated in subsection 3.2 is 5 m/s, the airspeed accelerated up to 6.3 m/s inside the diffuser, which means the flow accelerates about 26%. Figure 6 shows the axial air velocity of the center-line axis of the hollow diffuser relative to the upstream airspeed with respect to the dimensionless axial position.

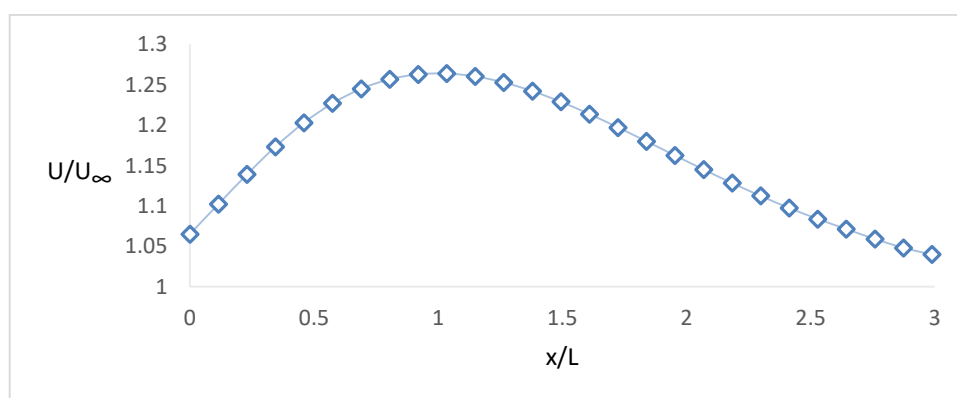

Fig. 6. Performance New diffuser configuration performance

4.2 Performance of a Turbine With a Diffuser With a Flange

The increase in the torque occurred when the flanged-diffuser shrouds the turbine is clearly shown in Figure 7; there is an increase in torque that range between 4 % and 107% compared to the bare turbine; this result agrees with results from previous researches conducted by Ohya *et al.*, [16]. Figure 7 also emphasizes the role of the flange because the torque's increase is negligible when the flange is removed from the shroud part, which agrees with the experimental work results from Ohya *et al.*, [7,16] that also emphasize the importance of the flange.

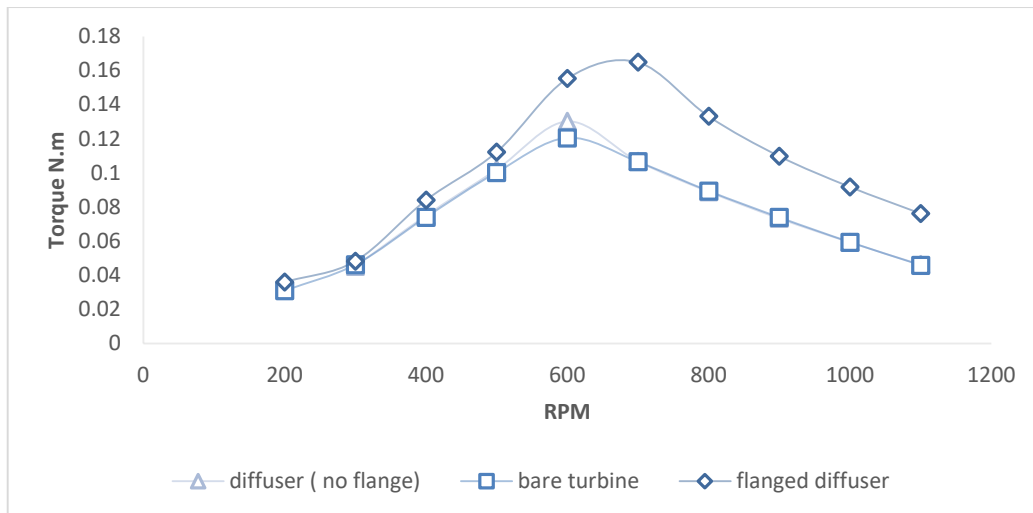

Fig. 7. Bare turbine vs. wind lens performance at upstream speed 5 m/s.

4.3 Performance of a Turbine With a Diffuser With Flange Only

The main objective of this research is to investigate whether removing the diffuser from the shroud and keeping only the flange would increase the system performance or not. Reapplied the same numerical model to the system after removing the diffuser, the maximum turbine torque has reduced by 20%. The pressure contours across the turbine have been plotted as shown in Figure 8 for the following cases, respectively, a bare turbine, a turbine with a diffuser only, a turbine with a flanged diffuser, and a turbine with a flange only. The following points could be observed.

In Figure 8a and Figure 8b, the pressure contours of both bare turbine case and turbine with diffuser only case is similar, which might explain the negligible effect of the diffuser only case.

In Figure 8c, which shows the pressure contours of the flanged diffuser, three things could be observed: First, a high-pressure zone is formed upstream of the turbine plane, which is a favorable thing for wind energy extraction. Second, the low-pressure zone behind the diffuser as well as the turbine, has been extended, which is also a favorable condition for a wind turbine. Thirdly: The flange has formed a high-pressure zone in front of it. The first two points might explain why this configuration has a superior performance to the bare turbine.

Figure 8d, which shows the flange only cases, the ring flange has also formed a high-pressure zone, like the flange in Figure 8c. However, differently, in Figure 8c, the diffuser walls act as a separator between the high-pressure zone and the turbine, and in the case of the flange only cases (Figure 8d), there is no separator, which resulted in a high-pressure zone behind the turbine which is not a favorable condition, and that might explain why quantitatively, the turbine torque has reduced.

By further examined the velocity vector of the final case where the torque reduction happened, it is noticed, as shown in Figure 9a, that because the flange act as an obstacle, the airflow trying to avoid the obstacle had accelerated in regions close to the flange's edge. Hence replacing the turbine behind the flange instead of its front would be reasonable to take advantage of this flow acceleration.

The results for this new configuration, as shown in Figure 9b, depicts an improvement in the performance. The torque of the turbine with the flange in the front has increased 33% compared to the bare turbine.

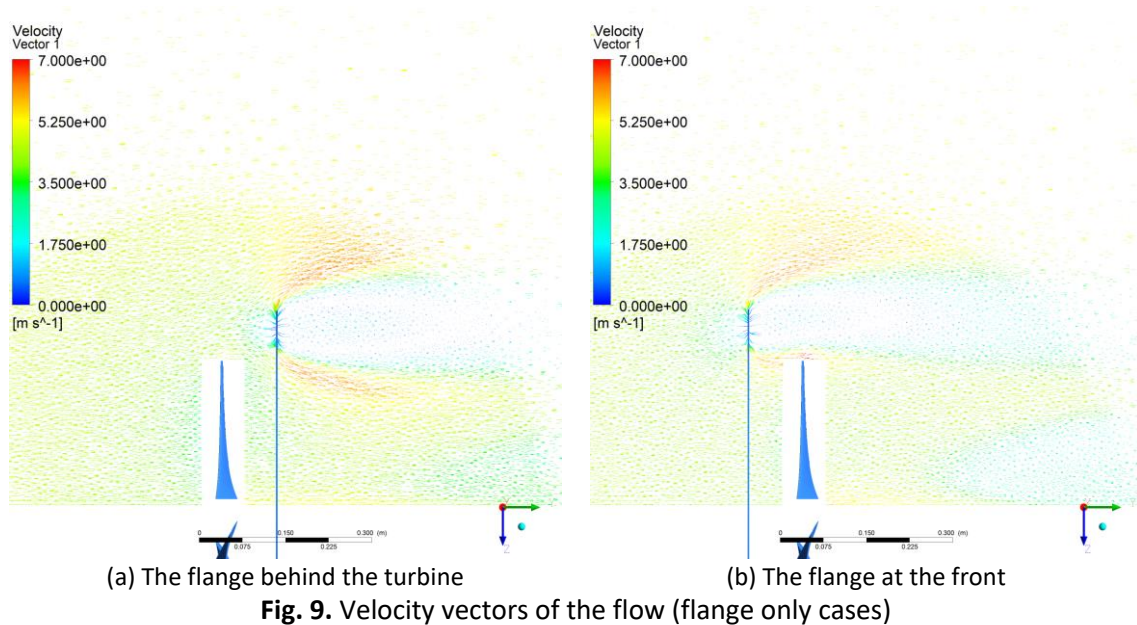
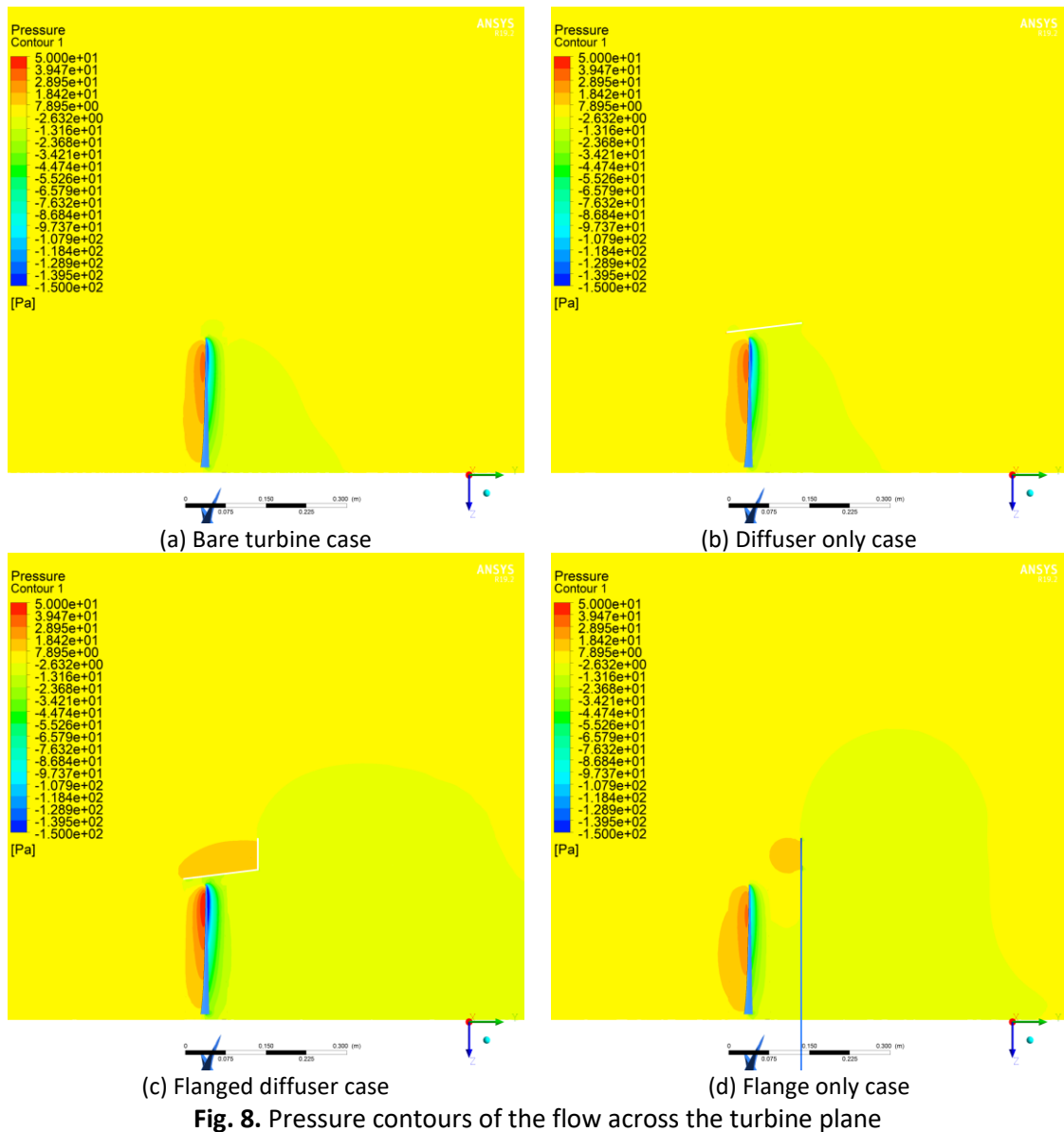

The ringed flange behaves as an obstacle which formed a high-pressure zone in front of it since the upstream flow avoids this high-pressure zone and deflects inside and outside the ring. It explains why a turbine placed inside the ring might have an improvement in the performance. Figure 10 shows the results of the bare turbine compared to the new configuration. The new system has lesser power compared to the traditional wind lens; however, it is less complicated and uses lesser materials, which favorably, in turn, may reduce the cost.

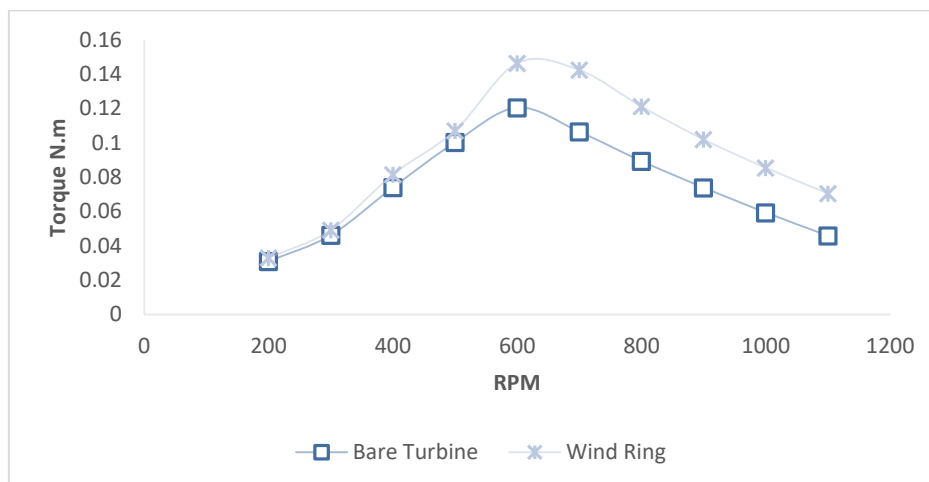

Fig. 10. The torque of bare turbine vs. shrouded turbine (flange at the front)

5. Conclusion

This research has successfully concluded that a turbine shrouded with a diffuser and flange has a superior performance compared to the bare turbine.

A new simpler configuration that could accelerate the flow and is superior to the bare turbine's performance has been proposed in this research work. The configuration consists of a ringed flange placed at the front of the turbine instead of its rear.

The new configuration introduced in this research work has shown a better performance of about 33% over a bare turbine. Even though the increase in the performance is still inferior to the conventional diffuser-flange shroud, which is superior to the bare turbine by 54.7%, this new design is much simpler and uses lesser materials, which favorably, may reduce the cost.

For future work, it is proposed to conduct a wind tunnel test. Experimental works have been recognized as well-tested instrumentation to conduct the research [24-26]. An exergy study is also required to know whether the system is economically worthy or not.

Acknowledgment

The authors would like to express gratitude to Aerolab UTM for providing valuable technical supports to conduct this research project. The authors are also indebted to the UTM-Research University Grant, Tier 2 Vot Number Q.J130000.2651.16J33.

References

- [1] Ali Kadhemi, Athraa, Noor Izzri Abdul Wahab, and Ahmed N Abdalla. "Wind energy generation assessment at specific sites in a Peninsula in Malaysia based on reliability indices." *Processes* 7, no. 7 (2019): 399. <https://doi.org/10.3390/pr7070399>
- [2] Islam, M. R., Rahman Saidur, and N. A. Rahim. "Assessment of wind energy potentiality at Kudat and Labuan, Malaysia using Weibull distribution function." *Energy* 36, no. 2 (2011): 985-992. <https://doi.org/10.1016/j.energy.2010.12.011>

- [3] Kadhem, Athraa Ali, Noor Izzri Abdul Wahab, Ishak Aris, Jasronita Jasni, and Ahmed N. Abdalla. "Advanced wind speed prediction model based on a combination of weibull distribution and an artificial neural network." *Energies* 10, no. 11 (2017): 1744.
<https://doi.org/10.3390/en10111744>
- [4] Manwell, J. F., J. G. McGowan, and A. L. Rogers. "Wind turbine design and testing." *Wind Energy Explained. John Wiley & Sons, Ltd, Hoboken, New Jersey, United States* (2009): 311-357.
<https://doi.org/10.1002/9781119994367>
- [5] Aranake, Aniket C., Vinod K. Lakshminarayan, and Karthik Duraisamy. "Computational analysis of shrouded wind turbine configurations using a 3-dimensional RANS solver." *Renewable Energy* 75 (2015): 818-832.
<https://doi.org/10.1016/j.renene.2014.10.049>
- [6] Squire, L. C. "Modern Compressible Flow: with historical perspective—Second edition. JD Anderson. McGraw-Hill Book Co (UK), McGraw Hill House, Shoppenhangers Road, Maidenhead, Berks, SL6 2QL. 1990. 650 pp. Illustrated.£ 18.95." *The Aeronautical Journal* 95, no. 947 (1991): 248-248.
- [7] Ohya, Yuji, Takashi Karasudani, Akira Sakurai, and Masahiro Inoue. "Development of a high-performance wind turbine equipped with a brimmed diffuser shroud." *Transactions of the Japan Society for Aeronautical and space sciences* 49, no. 163 (2006): 18-24.
<https://doi.org/10.2322/tjsass.49.18>
- [8] Klistafani, Y., and M. I. Mukhsen. "Development of a Shrouded Wind Turbine with Various Diffuser Type Structures." In *IOP Conference Series: Materials Science and Engineering*, vol. 676, no. 1, p. 012040. IOP Publishing, 2019.
<https://doi.org/10.1088/1757-899X/676/1/012040>
- [9] Aranake, Aniket, Vinod Lakshminarayan, and Karthik Duraisamy. "Computational analysis of shrouded wind turbine configurations." In *51st AIAA Aerospace Sciences Meeting including the New Horizons Forum and Aerospace Exposition*, p. 1211. 2013.
<https://doi.org/10.2514/6.2013-1211>
- [10] Ohya, Yuji, Takashi Karasudani, Tomoyuki Nagai, and Koichi Watanabe. "Wind lens technology and its application to wind and water turbine and beyond." *Renewable Energy and Environmental Sustainability* 2 (2017): 2.
<https://doi.org/10.1051/rees/2016022>
- [11] Igra, Ozer. "Shrouds for aerogenerators." *AIAA Journal* 14, no. 10 (1976): 1481-1483.
<https://doi.org/10.2514/3.61486>
- [12] Gilbert, Barry L., Richard A. Oman, and Kenneth M. Foreman. "Fluid dynamics of diffuser-augmented wind turbines." *Journal of Energy* 2, no. 6 (1978): 368-374.
<https://doi.org/10.2514/3.47988>
- [13] Garc Por Alejandro. "Por Alejandro García Montaño." *IPENZ Transactions* 26 (1999): 13–19.
- [14] Gaden, David LF, and Eric L. Bibeau. "A numerical investigation into the effect of diffusers on the performance of hydro kinetic turbines using a validated momentum source turbine model." *Renewable Energy* 35, no. 6 (2010): 1152-1158.
<https://doi.org/10.1016/j.renene.2009.11.023>
- [15] Abe, Ken-ichi, and Yuji Ohya. "An investigation of flow fields around flanged diffusers using CFD." *Journal of wind engineering and industrial aerodynamics* 92, no. 3-4 (2004): 315-330.
<https://doi.org/10.1016/j.jweia.2003.12.003>
- [16] Ohya, Yuji, and Takashi Karasudani. "A shrouded wind turbine generating high output power with wind-lens technology." *Energies* 3, no. 4 (2010): 634-649.
<https://doi.org/10.3390/en3040634>
- [17] Wang, Wen-Xue, Terutake Matsubara, Junfeng Hu, Satoru Odahara, Tomoyuki Nagai, Takashi Karasutani, and Yuji Ohya. "Experimental investigation into the influence of the flanged diffuser on the dynamic behavior of CFRP blade of a shrouded wind turbine." *Renewable Energy* 78 (2015): 386-397.
<https://doi.org/10.1016/j.renene.2015.01.028>
- [18] Lipian, Michal, Ivan Dobrev, Maciej Karczewski, Fawaz Massouh, and Krzysztof Jozwik. "Small wind turbine augmentation: Experimental investigations of shrouded-and twin-rotor wind turbine systems." *Energy* 186 (2019): 115855.
<https://doi.org/10.1016/j.energy.2019.115855>
- [19] Göldenbott, Uli, Yuji Ohya, Shigeo Yoshida, and Peter Jamieson. "Aerodynamic interaction of diffuser augmented wind turbines in multi-rotor systems." *Renewable Energy* 112 (2017): 25-34.
<https://doi.org/10.1016/j.renene.2017.05.014>
- [20] Liu, Jie, Mengxuan Song, Kai Chen, Bingheng Wu, and Xing Zhang. "An optimization methodology for wind lens profile using computational fluid dynamics simulation." *Energy* 109 (2016): 602-611.
<https://doi.org/10.1016/j.energy.2016.04.131>

-
- [21] Abdelwaly, Mona, Hesham El-Batsh, and Magdy Bassily Hanna. "Numerical study for the flow field and power augmentation in a horizontal axis wind turbine." *Sustainable Energy Technologies and Assessments* 31 (2019): 245-253.
<https://doi.org/10.1016/j.seta.2018.12.028>
- [22] Takeyeldein, M. M. "Wind Turbine Design Using Thin Airfoil SD2030." PhD diss., Kyushu University, 2019.
<https://doi.org/10.5109/2321003>
- [23] Marten, D. "QBlade Guidelines v0. 95." *Technical University of Berlin, Berlin, Technical Report No. TUB-2015-1 10* (2015).
- [24] Dahalan, Md Nizam, Ahmad Fitri Suni, Iskandar Shah Ishak, N. A. R. Nik Mohd, and Shabudin Mat. "Aerodynamic study of air flow over a curved fin rocket." *Journal of Advanced Research in Fluid Mechanics and Thermal Sciences* 40, no. 1 (2017): 46-58.
- [25] Ishak, Iskandar Shah, and Muhammad Fitri Mougamadou Zabaroulla. "Effects Of Helicopter Horizontal Tail Configurations On Aerodynamic Drag Characteristics." *Jurnal Teknologi* 79, no. 7-4 (2017).
<https://doi.org/10.11113/jt.v79.12267>
- [26] Ishak, Iskandar Shah, Shuhaimi Mansor, M. L. Tholudin, and M. R. A. Rahman. "Numerical Studies on Unsteady Helicopter Main-Rotor-Hub Assembly Wake." *Journal of Advanced Research in Fluid Mechanics and Thermal Sciences* 47, no. 1 (2018): 190-200.