

## Reduction of PAPR using Huffrith Algorithm with Different Digital Modulation in NOMA System

Nur Asfarina Idrus<sup>1</sup>, Azlina Idris<sup>1,\*</sup>, Nur Idora Abdul Razak<sup>1</sup>, Aidatul Julia Abd Jabar<sup>1</sup>, Mohammad Basuki Rahmat<sup>2</sup>

<sup>1</sup> Wireless Communication Technology Research Group (WiCoT), School of Electrical Engineering, College of Engineering, Universiti Teknologi MARA (UiTM) Shah Alam, 40450 Shah Alam, Selangor, Malaysia

<sup>2</sup> Politeknik Perkapalan Negeri Surabaya (PPNS), Jl. Teknik Kimia, Kampus ITS, Keputih, Sukolilo Surabaya Jawa Timur, Indonesia

### ARTICLE INFO

#### Article history:

Received 5 February 2025

Received in revised form 21 July 2025

Accepted 10 September 2025

Available online 18 June 2026

#### Keywords:

Huffrith algorithm, Non-Orthogonal Multiple Access (NOMA), Quadrature Amplitude Modulation (QAM), Amplitude Phase Shift Keying (APSK), Peak-to-peak Average Ratio (PAPR)

### ABSTRACT

More efficient radio access approaches are needed for a full-scale deployment of sixth generation (6G) wireless systems because of the huge interconnectedness and rising needs of different services and data-hungry applications. Regarding this, academics and industry have recently been paying more and more attention to non-orthogonal multiple access, or NOMA. Because NOMA has a higher spectrum efficiency than orthogonal multiple access (OMA) approaches, it is suitable for 6G and beyond. Since OMA plan is unable to adequately enable huge connectivity such as IoT, NOMA has been regarded as a vital scheme. In this paper, QAM and APSK digital modulation techniques have been examined, utilizing 256 and 512 orders, respectively. As a result, APSK improves power efficiency rather than negatively impacting it. Huffrith is a new formulation of algorithm approach that can reduce PAPR more effectively than the conventional scheme. Simulation results show that the NOMA system with the 512-APSK modulation scheme achieves a 9.45 dB PAPR reduction and a 3.57% improvement over the OMA system.

## 1. Introduction

Beyond-6G network solutions must be very agile and resilient, as well as capable of providing ubiquitous coverage. This infrastructure's capabilities for flexible deployment and rapid service recovery are a valuable addition [1]. The 6G wireless communication standard has undergone two revisions, Rel-15 and Rel-16, with specifications yet to be released by the end of 2019. Rel-15 specifies basic functionalities such as initial access, channel structure, multi-antennas, and channel coding, which can meet some of IMT-2020's performance requirements. Several new technologies and scenarios are introduced to expand the use cases of 6G networks and fully meet all major performance requirements of IMT-2020, such as non-orthogonal multiple access (NOMA), ultra-dependable and low-latency connection, vehicle-to-everything (VX2) communication, unlicensed band operation, integrated access and backhaul, terminal power savings, and positioning. The

\* Corresponding author.

E-mail address: [azlina831@uitm.edu.my](mailto:azlina831@uitm.edu.my)

fundamental characteristics of a 6G network are low latency, massive connectivity for Internet-of Things (IoT), and higher data rates [2]. The key obstacles include limited coverage and application situations, as well as a large disparity between available bandwidth and requests. Furthermore, 6G can serve a diverse range of applications to satisfy the needs of the information society during the next decade (2020-2030). There are three major use cases: microsecond delay 99.999% level of ultra-reliable low-latency communications (uRLLC), million connections of massive machine type communications (mMTC), and Gbps speed of enhanced mobile broadband (eMBB) [3]. It is expected that the commercial deployment of 6G networks around the world, whether in stand-alone or non-stand-alone mode, with the 4G system serving as the anchor network, will have a significant impact on culture, the global economy, and human daily life. Like its predecessors, the 6G standard will continue to develop after 2020 to expand the deployment scenarios and further optimize the features, such as unmanned aerial vehicles, satellite communications, and non-terrestrial networks [4].

One of the essential components of wireless communication systems, multiple access, has a big influence on latency, system throughput, and spectrum utilization. Multiple access, as used in cellular radio, is a method that allows several users to share a single radio resource to create communication linkages with a base station (BS) [5]. Nonorthogonal multiple access (NOMA) has recently emerged as a promising multiple access strategy for significantly enhancing communication network spectral efficiency. NOMA techniques have recently been deployed in small-cell networks, allowing users to access channels non-orthogonally via power-domain multiplexing or code-domain multiplexing. Unlike traditional OMA systems, which allot one subcarrier to only one user, NOMA allows numerous users to share the same subcarriers, introducing co-user interference [6], [7] and [8]. NOMA's better spectrum efficiency emerges from its smart reuse of network resources, which involves multiplexing several users' messages in the same subchannel at the transmitter while generating effective signal identification algorithms at the receivers. As a result, NOMA necessitates a new set of physical-layer transmission, MAC, and network resource allocation algorithms. Recent scientific developments in this area clearly highlight this tremendous possibility. A low-complexity power control using a tree search algorithm and a sequential interference cancellation (SIC) receiver. Though there are some initial studies on resource management in NOMA systems, they have mainly focused on power allocation for power-domain NOMA. Other types of network resources in both frequency and code dimensions can be further explored in NOMA networks to increase access network capacity [9].

In contrast, some scholars present various analyses and research gaps. So, in this paper more focusing the various types of digital modulation and compare them using the contribution approach. The simulation findings help to explain the significance of the research.

## 2. Methodology

The NOMA system blocks diagram contribution mechanism, as shown in Figure 1. The 512-APSK digital modulation can support high-speed data transmission in wireless communications, and encoded the Huffrith algorithm portion, generated the input data during random transmission from sender to receiver. Essentially, the approach involved a block coding sender-to-receiver technique to technology improvement for maintaining the signal being sent. As technology improves, word block coding refers to a technique that converts a signal into a trustworthy signal for transmission. After then, the user's signal is transmitted via a NOMA encoder and further combined using a cyclic prefix and a Fourier transform.

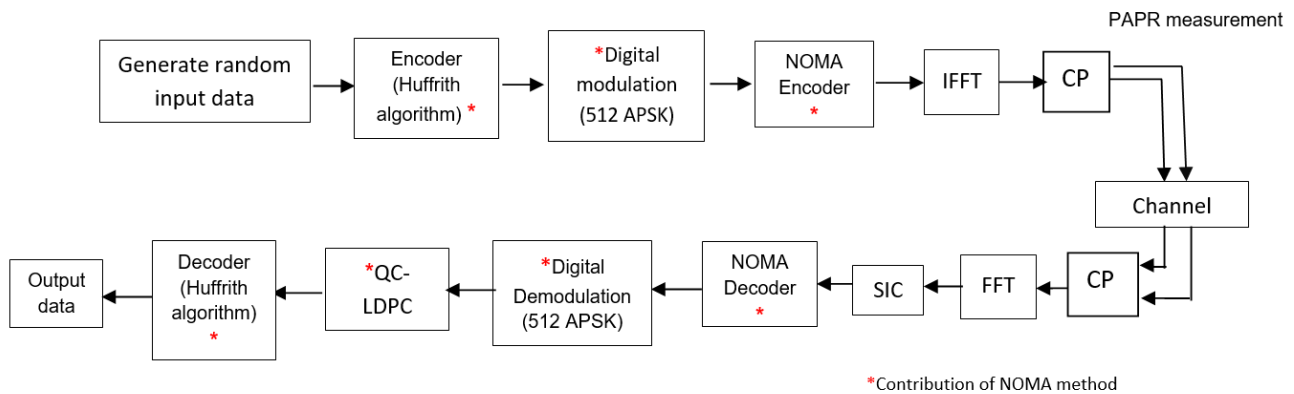

**Fig. 1.** NOMA system block diagram with contributions method [10]

More specifically, this study used the NOMA system to solve problems, such as high-power efficiency and high side lobes in the frequency. Furthermore, NOMA has been proposed to meet the requirements for 6G networks, which can enable vast connectivity for wireless access. NOMA increases the numerous users number that can support system [11]. The proposed NOMA strategy for the system is primarily intended to support many users while lowering PAPR as compared to the NOMA system. Occasionally, the NOMA system produces significant PAPR, reducing the efficiency of the transmitter's power amplifier. Following that, the user's signal is transferred via a NOMA encoder and then concatenated with a cyclic prefix and a Fourier transform. Cyclic prefixes have the capacity to eliminate Inter-Symbol Interference (ISI) in a broadcast signal multipath channel. As a result, power efficiency measures how well this component operates while it travels through the receiver and Rayleigh channel. The signal enforces a channel size to prevent overlapping. Thus, the signal is in the frequency domain during its transmission.

Superposition coding, with Quasi Cyclic Low Density Parity Check (QC-LDPC) as the error correction code and SIC as the process reverse, will be used. The performance completes the multi-user connection to eliminate increased signal interference. The system has the ability to reduce computational complexity [12]. The last steps will involve discussing all the graph results and determining whether the strategy contributed to this research reduced PAPR.

### 2.1 Non-Orthogonal Multiple Access (NOMA)

NOMA emerged as the top competitor for 6G due to its high spectrum efficiency. This system has been regarded as an essential scheme for supporting large connections, such as IoT because of this advantage in NOMA, that cannot be supported well by the OMA or OFDM schemes. In NOMA, two or more users are coupled together and assigned varied power within the same resource, such as the time, frequency, or spreading code [13], [14] and [6]. Users of the input signal is represented as [15]

$$y_i = h_i \sqrt{a_{\text{huffrith}}} x_i \quad (1)$$

where the complex channel coefficient between base stations and users is indicated by  $h_i$ .  $x_i$  indicates the inter-cell interference-added Gaussian noise in the receiver. The peak-to-peak average ratio, or PAPR, is stated as follows in dB: [16]

$$PAPR_{dB} = 10 \log_{10} \frac{\text{Maximum}[|y_i(t)|^2]}{\frac{1}{T} \int_0^T [|y_i(t)|^2] dt} \quad (2)$$

where  $T$  is the period of the NOMA symbol. The reduction method's effectiveness is indicated by an important indicator called the complementary cumulated distribution function (CCDF). The CCDF random variable  $X$  as expressed by the following equation, is estimated by the CCDF measurement: [17]

$$X = \frac{p}{E(p)} \quad (3)$$

where  $p$  is the instantaneous power of the signal in Watts. Meanwhile,  $E(p)$  measure the mean power of the signal in Watts. The CCDF shows the probability of a signal's instantaneous power being a set level higher than its average power.

## 2.2 Huffrith Algorithms

Arithmetic and Huffman equations are combined to create the Huffrith algorithm. This is an addition to earlier study [10], which found that combining the two would enhance it. This is how the Huffrith algorithm is expressed.

$$a_{huffrith} = \frac{255[a - P_1(a)]}{P_2} \quad (4)$$

Assume that  $a$  is both the total number of bits per symbol and the number of symbols in the NOMA system. The probability of a codeword is  $P_1$  and  $P_2$ . One method of modulation that is used to encode strings is the Huffrith algorithm. As a result, Huffrith also encoded the data, which is a conversion procedure used for data transmission, compression, and storage.

## 2.3 Quasi-cyclic low density parity check (QC-LDPC)

The quasi-cyclic parity check matrix or QC-LDPC, can be replaced in the LDPC code structure with a simple linear shift. The focus of coding research has switched to register encoding since it requires less hardware complexity and storage space to accomplish. A binary QC-LDPC code is defined as the null space of an array of sparse circulants of the same size. A QC-LDPC's parity check matrix  $H$  is defined by the base graph and considering the method of shift coefficients ( $P_{i,j}$ ). A dimension of zero matrix and circulant permutation matrix is  $z \times z$  are used as substitutes for each number bits 1s and 0s in a basis graph [18], [19] and [20]. Furthermore, considering both positive integers  $m_b$  and  $n_b$ , as well as  $m_b \leq n_b$ , the QC-LDPC is represented as an array of  $z \times z$  circulants in the form of  $m_b \times n_b$ , as indicated by formula (5).

$$H = \begin{bmatrix} I(a_{1,1}) & I(a_{1,2}) & \dots & I(a_{1,n_b}) \\ I(a_{2,1}) & I(a_{2,2}) & \dots & I(a_{2,n_b}) \\ \vdots & \vdots & \ddots & \vdots \\ I(a_{m_b,1}) & I(a_{m_b,2}) & \dots & I(a_{m_b,n_b}) \end{bmatrix} \quad (5)$$

Meanwhile, there is the unit matrix that shifts to the corresponding location. Written as a matrix  $E(H)$ , the cycle permutation matrix is additionally known as a quasi-cyclic basis matrix [20], [12], as explained in the following method:

$$E(H) = \begin{bmatrix} a_{1,1} & a_{1,2} & \dots & a_{1,n_b} \\ a_{2,1} & a_{2,2} & \dots & a_{2,n_b} \\ \vdots & \vdots & \ddots & \vdots \\ a_{m_b,1} & a_{m_b,2} & \dots & a_{m_b,n_b} \end{bmatrix} \quad (6)$$

As a result, each item in matrix  $E$  is known as a shift value. Noted that the parity check matrix  $H$  can be created by expanding the  $m_b \times n_b$  exponent matrix  $E(H)$ . This called the process of photography construction [21] and [22].

### 3. Results and Analysis

The simulation section discusses the system's capacity with the parameters evaluated and listed in Table I. Simulation generated using the MATLAB 2021Rb programmed. The NOMA simulation parameters for generating random input data with 1024 subcarriers per resource block and FFT size via the Rayleigh fading channel. The existing multiple access approaches can be classified as NOMA techniques based on whether the same time or frequency resource can be used by more than one user. NOMA supports a maximum FFT size of 2048. The Huffrith Algorithm was used in the simulation to compare different modulation strategies and access methods. The Huffman Algorithm is an addition to the NOMA system for evaluating PAPR performance. Modulation order for various types of modulation techniques, including 256-QAM, 512-QAM, 256-APSK, and 512-APSK.

**Table 1**  
 Simulation parameter of NOMA system [10]

Parameter	Value
Subcarrier per resource block	1024
Channel	Rayleigh fading
Sampling factor, $n$	1.12
FFT size	2048
Cyclic prefix	256
Modulation technique	256-QAM, 512-QAM, 256-APSK, 512-APSK

#### 3.1 Different Modulation Technique Simulation

Figure 2 portrays the proposed method for differentiating modulation techniques in the NOMA system between QAM and APSK. Non-Orthogonal Multiple Access (NOMA) and Orthogonal Multiple Access (OMA) distinguish themselves as well as one another to determine which network system is preferable by using the contribution approach [23]. The simulation results were used to analyse the PAPR effect in relation to the complementary cumulative density function (CCDF). The modulation order numbers, which are 256 and 512, differ for both signalling. The accurate signals were validated and verified using the simulated system with different coding methods. The NOMA systems with QC-LDPC as the error correction mode was enhanced by the signal with the lowest PAPR value. According to the figure below, 512-APSK with pink line has the lowest PAPR compared to 256-QAM, 512-QAM, and 256-APSK.

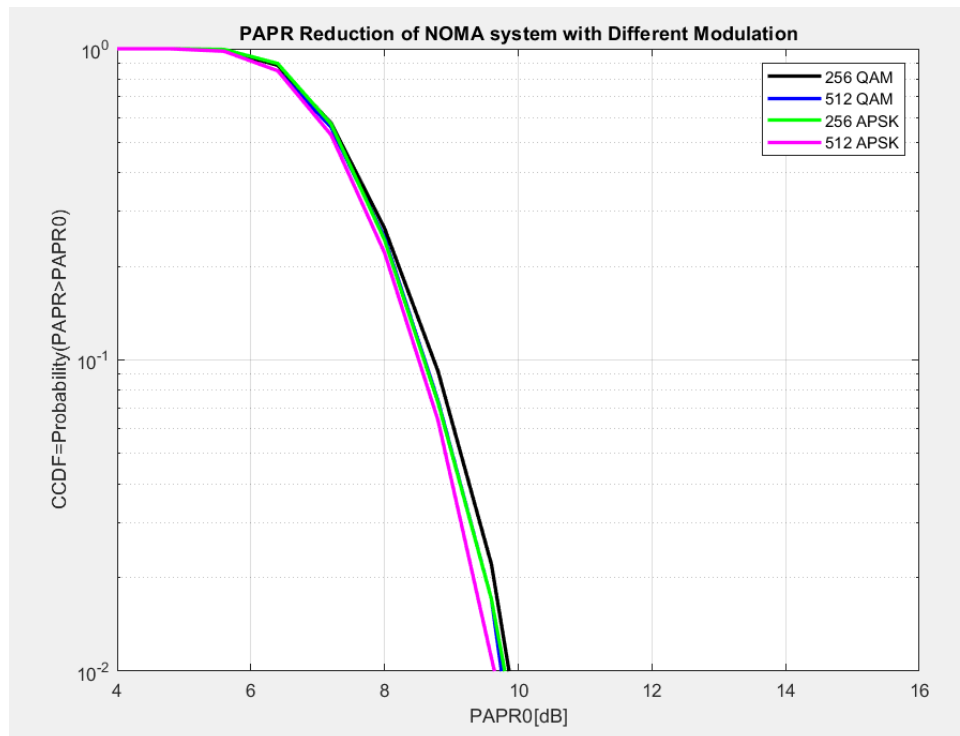

**Fig. 2.** The PAPR of NOMA system by differentiate modulation technique between QAM versus APSK

The measurements for both systems using the coding schemes were listed in Table II. Nevertheless, as that is the most typical range to observe the PAPR values, they were simulated at 1000 symbols. However, the modulation technique differs between QAM and APSK in the NOMA. Refer to the PAPR readings, it appears that 512-APSK has the lowest PAPR of 3.08% improvement at 9.45dB than 512-QAM at 9.75dB. Following that, 256-QAM is 1.02% at 9.7dB compared with 256-APSK is 9.8dB. APSK has been found to produce less PAPR than other modulation technique, which more applicable reducing the PAPR in NOMA system. The identical methodology, nevertheless, is also described in [10] as being APSK modulation more dependable and appropriate for NOMA.

**Table 2**  
 Differentiate modulation techniques in NOMA

Modulation Technique	NOMA system		
	Modulation Order	PAPR Values (dB)	Improvement (%)
QAM	256	9.7	1.02
	512	9.75	-
APSK	256	9.8	-
	<b>512</b>	<b>9.45</b>	<b>3.08</b>

### 3.2 Different Multiple Access Using Huffrith Algorithm

Figure 3 compares the type of multiple access of PAPR performance in a NOMA system using the Huffrith algorithm. Three primary types of multiple access are taken into consideration in the PAPR analysis: OFDM, OMA, and NOMA. The simulations significant contribution is its greater emphasis on

the NOMA network system. Compare the data, it appears that the NOMA system leads with 10.8 dB. Meanwhile, OMA has outpaced OFDM, yielding 11.4dB and 12.2dB. The NOMA graph below shows black line, indicates lower PAPR performance.

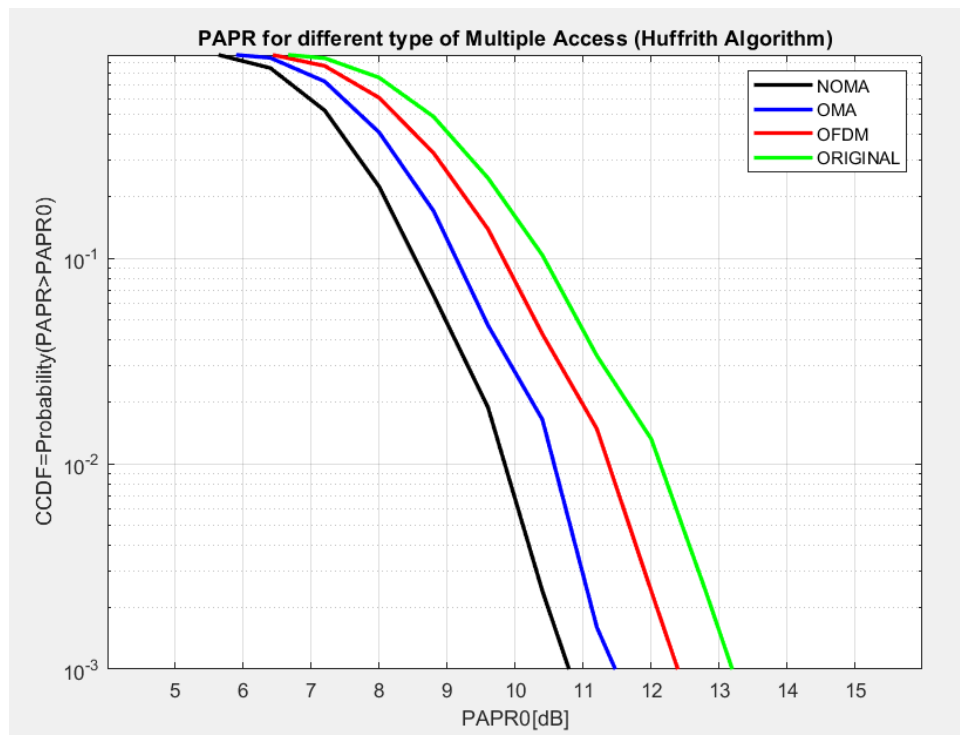

**Fig. 3.** The Huffrith Algorithm is implemented to differentiate the Multiple Access subtype in the NOMA systems PAPR

Table 3 demonstrates that at 10.8 dB, the NOMA system outperforms the PAPR reduction of the OMA and OFDM modulation techniques by 18.18%. Meanwhile, OMA gains 13.64% at 11.4 dB, while OFDM gains 6.06% at 12.4 dB respectively. According to the findings, NOMA improves PAPR performance and is now employed as input signal digital modulation for the Huffrith method across the system. The PAPR problem in NOMA waveforms was reduced by using an effective method.

**Table 3**  
 Differentiate modulation access in NOMA system

Algorithm	NOMA system		
	Multiple Access	PAPR Values (dB)	Improvement (%)
Huffrith	<b>NOMA</b>	<b>10.8</b>	<b>18.18</b>
	OMA	11.4	13.64
	OFDM	12.4	6.06
	Original	13.2	-

## 4. Conclusions

The simulation ran and tested the Huffrith Algorithm with several digital modulations to address the high PAPR issue in NOMA systems. This section evaluates the effectiveness of APSK modulation and compares it to the QAM modulation method. Following examining the NOMA and OMA schemes, the current study produced the following conclusions: the suggested methodology has the potential to significantly increase the PAPR performance. Simulation findings demonstrated that the suggested approach achieves a 9.45dB PAPR reduction and a 3.57% improvement over 256-QAM and 512-QAM, exceeding conventional evolutionary computation techniques with 512-APSK scheme implementation. This approach, NOMA system improves the PAPR measurement with 18.18% to 10.8 dB. Meanwhile, the optimal modulation technique for NOMA is 512-APSK, stated the NOMA is a better multiple access technique than OMA, precisely by using APSK technique as it improved the reasonable data rate and the PAPR is reduced.

## Acknowledgement

This study has been funded by a Fundamental Research Grant (FRGS/1/2023/TK07/UITM/01/1) from the Ministry of Higher Education and Universiti Teknologi MARA (600-RMC/FRGS 5/3 (005/2023)). We are greatly gratitude that the College of Engineering, Universiti Teknologi MARA Shah Alam provided us permission for carrying out this research project.

## References

- [1] Cao, Xianbin, Peng Yang, Mohamed Alzenad, Xing Xi, Dapeng Wu, and Halim Yanikomeroglu. "Airborne communication networks: A survey." *IEEE Journal on Selected Areas in Communications* 36, no. 9 (2018): 1907-1926. <https://doi.org/10.1109/jsac.2018.2864423>
- [2] Saad, Walid, Mehdi Bennis, and Mingzhe Chen. "A vision of 6G wireless systems: Applications, trends, technologies, and open research problems." *IEEE network* 34, no. 3 (2019): 134-142. <https://doi.org/10.1109/mnet.001.1900287>
- [3] Shafie, Akram, Nan Yang, Chong Han, Josep Miquel Jornet, Markku Juntti, and Thomas Kürner. "Terahertz communications for 6G and beyond wireless networks: Challenges, key advancements, and opportunities." *IEEE Network* 37, no. 3 (2022): 162-169. <https://doi.org/10.1109/mnet.118.2200057>
- [4] I. T. Union, "Network 2030 - Gap Analysis of Network 2030 New Services, Capabilities and Use cases," *ITU-T FG NET2030 Tech. Rep.*, no. June, 2020.
- [5] Ghous, Mujtaba, Ahmad Kamal Hassan, Ziaul Haq Abbas, Ghulam Abbas, Aseel Hussien, and Thar Baker. "Cooperative power-domain NOMA systems: an overview." *Sensors* 22, no. 24 (2022): 9652. <https://doi.org/10.3390/s22249652>
- [6] Hussain, Muhammad, and Haroon Rasheed. "Nonorthogonal multiple access for next-generation mobile networks: A technical aspect for research direction." *Wireless Communications and Mobile Computing* 2020 (2020): <https://doi.org/10.1155/2020/8845371>
- [7] Baghani, Mina, Saeedeh Parsaeefard, Mahsa Derakhshani, and Walid Saad. "Dynamic non-orthogonal multiple access and orthogonal multiple access in 5G wireless networks." *IEEE Transactions on Communications* 67, no. 9 (2019): 6360-6373. <https://doi.org/10.1109/tcomm.2019.2919547>
- [8] Liu, Yuanwei, Shuowen Zhang, Xidong Mu, Zhiguo Ding, Robert Schober, Naofal Al-Dhahir, Ekram Hossain, and Xuemin Shen. "Evolution of NOMA toward next generation multiple access (NGMA) for 6G." *IEEE Journal on Selected Areas in Communications* 40, no. 4 (2022): 1037-1071. <https://doi.org/10.1109/jsac.2022.3145234>
- [9] Arachchillage, Udara Srimath S. Samaratunge, Dushantha Nalin K. Jayakody, Sanjay K. Biswash, and Rui Dinis. "Recent advances and future research challenges in non-orthogonal multiple access for 5G networks." In 2018 IEEE 87th Vehicular Technology Conference (VTC Spring), pp. 1-6. IEEE, 2018. <https://doi.org/10.1109/vtcspring.2018.8417843>
- [10] Idrus, Nur Asfarina, Azlina Idris, Nur Idora Abdul Razak, and Lusy Tunik Muharlisiani. "PAPR Reduction using Huffrith Algorithm with APSK Modulation Technique in 6G System." *Journal of Advanced Research in Applied Sciences and Engineering Technology* 32, no. 3 (2023): 273-281. <https://doi.org/10.37934/araset.32.3.273281>
- [11] Deraz, Shady A., Mohamed RM Rizk, Shawky Shaaban, and Karim H. Moussa. "Performance analysis of MIMO-

- NOMA systems based on dynamic user pairing scheme." In *Journal of Physics: Conference Series*, vol. 1447, no. 1, p. 012016. IOP Publishing, 2020. <https://doi.org/10.1088/1742-6596/1447/1/012016>
- [12] Idrus, Nur Asfarina, Azlina Idris, Nur Idora Abdul Razak, Idris Taib, and Lusy Tunik Muharlisiani. "Huffrith Algorithm with Quasi Cyclic Low Density Parity Check in NOMA Systems." *Journal of Advanced Research in Applied Sciences and Engineering Technology* 38, no. 1 (2024): 1-11. <https://doi.org/10.37934/araset.38.1.111>
- [13] López, Onel LA, Hirley Alves, and Matti Latva-Aho. "Distributed rate control in downlink NOMA networks with reliability constraints." *IEEE Transactions on Wireless Communications* 18, no. 11 (2019): 5410-5423. <https://doi.org/10.1109/twc.2019.2936188>
- [14] Tahira, Zanib, Hafiz M. Asif, Asim Ali Khan, Sobia Baig, Shahid Mumtaz, and Saba Al-Rubaye. "Optimization of non-orthogonal multiple access based visible light communication systems." *IEEE Communications Letters* 23, no. 8 (2019): 1365-1368. <https://doi.org/10.1109/lcomm.2018.2889986>
- [15] Murti, Fahri Wisnu, Rahmat Faddli Siregar, Muhammad Royyan, and Soo Young Shin. "Exploiting non-orthogonal multiple access in downlink coordinated multipoint transmission with the presence of imperfect channel state information." *International Journal of Communication Systems* 33, no. 14 (2020): e4533. <https://doi.org/10.1002/dac.4533>
- [16] Sharma, Mohit Kumar, and Arun Kumar. "PAPR Reduction in NOMA by Using Hybrid Algorithms." *Computers, Materials & Continua* 69, no. 1 (2021). <https://doi.org/10.32604/cmc.2021.017666>
- [17] Rashmi, N., and Mrinal Sarvagya. "The peak-to-average power ratio reduction using hybrid scheme with companding and discrete Hartley transform for orthogonal frequency division multiplexing system." *International Journal of Intelligent Enterprise* 9, no. 3 (2022): 303-317. <https://doi.org/10.1504/ijie.2022.123754>
- [18] Nguyen, Tram Thi Bao, Tuy Nguyen Tan, and Hanho Lee. "Efficient QC-LDPC encoder for 5G new radio." *Electronics* 8, no. 6 (2019): 668. <https://doi.org/10.3390/electronics8060668>
- [19] Daqin, Peng, Zhu Shumin, and Song Jing. "A novel construction of QC-LDPC codes based on combinatorial mathematics." *Procedia computer science* 131 (2018): 786-792. <https://doi.org/10.1016/j.procs.2018.04.256>
- [20] Hasani, Alireza. "High-throughput QC-LDPC codes for next-generation wireless communication systems." PhD diss., BTU Cottbus-Senftenberg, 2021. <https://doi.org/10.1109/access.2022.3141493>
- [21] Idris, Azlina, Nurul Aini Amran, Mohd Syarhan Idris, Idris Taib, Murizah Kassim, Suzi Seroja Sarnin, Wan Norsyafizan W. Muhammad, and Norsuzila Ya'acob. "Arithmetic and Huffman Coding using Quasi-Cyclic Low Density Parity Check Techniques with F-OFDMA for 5G System." *Int. J. Eng. Technol* 7 (2018): 16-18. <https://doi.org/10.14419/ijet.v7i3.15.17398>
- [22] Bocharova, Irina E., Boris D. Kudryashov, and Rolf Johannesson. "LDPC convolutional codes versus QC LDPC block codes in communication standard scenarios." In *2014 IEEE International Symposium on Information Theory*, pp. 2774-2778. IEEE, 2014. <https://doi.org/10.1109/isit.2014.6875339>
- [23] Chen, Zhiyong, Zhiguo Ding, Xuchu Dai, and Rui Zhang. "An optimization perspective of the superiority of NOMA compared to conventional OMA." *IEEE Transactions on Signal Processing* 65, no. 19 (2017): 5191-5202. <https://doi.org/10.1109/tsp.2017.2725223>