

A study on the microclimatic performance of courtyard and non-courtyard residential buildings in hot-arid climate

Open
Access

Markus Bulus^{1,2,*}, Lim Yaik-Wah², Malsiah Hamid²

¹ Department of Architecture, Faculty of Environmental Science, Kaduna State University, Kaduna Nigeria

² Department of Architecture, Faculty of Built Environment, Universiti Teknologi Malaysia, 81310 Skudai Johor, Malaysia

ARTICLE INFO

ABSTRACT

Article history:

Received 8 July 2017

Received in revised form 30 August 2017

Accepted 30 September 2017

Available online 14 October 2017

Scholars have opined that the courtyard is a passive architectural design element and that it can act as a microclimate modifier provided that its design requirements are not ignored. But despite the assertions, empirical studies on the microclimatic performance of a fully enclosed courtyard house and the non-courtyard house seems to be deficient, and the assumption that the Courtyard is a passive architectural design element needs to be substantiated. Therefore, the purpose of this study is to investigate the microclimatic performance of a fully enclosed courtyard and non-courtyard residential buildings. The main objective is to compare their microclimatic performances in order to draw a conclusion on the best option. Three Hobo Weather Data Loggers were used to collect climatic data in the buildings, and the third one was situated in the outdoor area as a benchmark. The climatic variables investigated are; air temperature and relative humidity. The fully enclosed courtyard residential building is seen to have a better air temperature difference of 2 °C to 4 °C and the relative humidity of 2 % to 6 %. In conclusion, the fully enclosed courtyard residential building has confirmed a more favorable microclimatic performance, and future studies towards its optimization are recommended.

Keywords:

Residential buildings, microclimate, courtyard, performance

Copyright © 2017 PENERBIT AKADEMIA BARU - All rights reserved

1. Introduction

The Intergovernmental Panel on Climate Change IPCC [1] has predicted that air temperature will be on the increase under all assessed emission situations. But the worry is that if air temperature will remain on the high side, what then can the professional architect do? Is he to remain resolute in his architectural design of buildings that lacks the passive design elements capable of mitigating the effect of high air temperature and continue to augment to the persistent challenge of greenhouse gas emissions as use of alternative means of electric generator remain the only sure option for obtaining the required power energy in buildings in most of the underdeveloped countries, most particularly in African Nations such as Nigeria, or, he should shift to passive architectural design.

* Corresponding author.

E-mail address: Markus Bulus (markusbulus8@gmail.com)

Studies in passive architecture have highlighted that passive architectural design is required in this century and that the use of the courtyard as a passive architectural design element may be one of the most suitable alternatives. According to Tablada [2], defined passive architecture as a strategy for obtaining cooling in buildings. He studied the effect of courtyard proportions on solar heat gain and energy requirement in the temperate climate of Rome and recommended the use of the courtyard as a concept that promotes good natural daylighting penetration in buildings, efficient ventilation in buildings, and thereby enhancing thermal comfort. Also, Akande [3] has agreed to this fact by concluding in his study that the use of passive design strategies such as; a good courtyard and building orientation can improve cooling in buildings naturally and most especially in the tropics.

Recently, scholars have conducted a plethora of studies highlighting that the courtyard has a lot of benefits and that the courtyard is climate-responsive [2,4-7]. Also, studies have shown that the courtyard microclimatic modifying potential must be clearly understood. Consequently, for the courtyard to fulfil its main climatic task such as enhancing cooling in buildings, more research effort towards understanding its microclimatic impact on the indoor thermal performance is necessary. More so, experimental studies on the microclimatic behaviour of a fully enclosed courtyard residential building and a non-courtyard house seem to be lacking, and the fact that the Courtyard is passive design elements needs to be validated.

Therefore, this study is to investigate the microclimate performance of a fully enclosed courtyard house and a non-courtyard house. The primary objective is to make a comparison between their microclimatic performances so as to make conclusions on the utmost alternative. This research uses the experimental methodology. Three (3) hobo weather data loggers (HWDL) were used. The uniqueness of this study is to the climatic variables studied (air temperature, and relative humidity) which has not been studied in Nigeria.

2. Literature Review

Countries that are located in the tropical zones and most particularly the underdeveloped countries have extreme heat problems in town and cities due to the retaining heat by structures if air circulation for cooling at night-time is insufficient [8]. In most of these zones, several of the housing are not fit for the residents due to inappropriate building design. And since their financial prudence cannot provide the required active means of cooling for the majority of their buildings, then, the comfort of the inhabitants hinge completely on the architectural design of buildings with passive strategies.

Most particularly in Nigeria, the architectural designs of residential buildings is in most cases not adaptable to the climatic requirements of the tropical zones. Structures are designed without due considerations for thermal comfort. Akande [3] argued that passive architectural design strategies must be employed if the quest for buildings that respond to the climatic requirements of buildings in the tropics is to be effectively addressed.

But amongst the numerous passive design strategy for buildings in the tropical climatic zones is the courtyard [9]. Scholars have studied the courtyard from different perspectives and defined it in different views [10-13]. But a critical review of the definitions mentioned “open”, “space”, “enclosed” and “wall” in one way or the other. Hence, Markus [14] made a synthesis of all their views and summarized as the courtyard is an open space enclosed with open walls. The courtyard has also been classified into two major categories; the fully enclosed, and the semi-enclosed courtyard [15].

Markus [16] has observed that the social advantages of the courtyard, within the courtyard and the building envelope, seems to have constituted a greater fraction of scholars’ interest rather than the issue of microclimate performance of the courtyard building. He argued that the courtyard and

the building microclimatic performance should be more paramount than its social benefits. But does the microclimatic performance of the courtyard residential building in any way better-off than the non-courtyard residential building? According to Meir [5], it is possible for the fully enclosed courtyards to contribute negatively to the microclimatic performance of the building if its microclimatic behavior and the appropriate use of its design variants are not fully understood.

Thermal distress in the courtyard buildings is determined by the climatic factors such as air temperature and relative humidity. The consequence of these factors on the building is directly proportional to the courtyard's dimensions and proportions and the orientation of the courtyard [17]. For optimum shading performance, the courtyard aspect ratio is a major determinant [18]. This factor has been revealed to be fundamental for air temperatures the courtyard building [19].

For the wind effects, the impact of air drive through the courtyard is very important in achieving thermal distress, both in the case of air flow in connection with the human skin and in the case of air from outside the courtyard space. The pattern of wind speed in the courtyard is defined by the orientation of the courtyard, and the creation of eddies air-speed directly perpendicular to the direction of the wind [20]. Such flow configurations are influenced by the courtyard's size and form [17]. If the distance between the courtyard surrounding is somewhat wide in the path of the wind, such that the height to width ratio is less than 0.5, moderately small regions of unstable air are created with a free movement through the courtyard. When the height to width ratio is larger, about 0.65, more eddies are created. Even though air velocity is generally lesser when space between successive building are very close to each other, such as when the height to width ratio is more than 0.65, the courtyard is seen to be well sheltered from the direct influence of the wind. Obviously, this situation offers the highest shelter to occupants from unwanted wind, but on the other hand, it may also impede on the ventilation effect of the courtyard.

Thus, while research effort towards investigating the microclimatic performance of the fully enclosed courtyard residential building in Nigeria appears to be lacking, more so is the efforts towards comparing the microclimatic potentials of the fully enclosed courtyard residential building with the non-courtyard residential building. This deficiency may be due to the over-dependence on the emphasis of the courtyard as a climate-responsive architectural design element by scholars [21]. But despite all these uncertainties, the courtyard still remains a very viable option towards delivering passive architecture and can constitute a vast portion of the building envelope. Therefore, the courtyard has a great ability for thermal comfort in buildings as long as the appropriate design awareness by architects is not lacking [22].

2.1 The Study Area

Kafanchan-Kaduna is located in the Southern part of Kaduna State in the North Central region of Nigeria-Africa. It has a latitude $9^{\circ}35'N$ and longitude $8^{\circ}17'E$ with a land mass of 32 km^2 (Google Earth, 2016). It has a population projection of 30,407 people [23]. And a tropical winter and summer climatic characteristics which are common of a typical tropical climate. The winter period starts in the month of April and ends in the month of October, while the summer period begins in the month of November to the month of April. The amount of annual rainfall received is in the range of 1140mm to 1204mm. The study area has the annual average air temperatures range of $36.4^{\circ}C$ [23]. Kafanchan is renowned for its large quantities of fuelwood [24] as depicted in Figure 1.

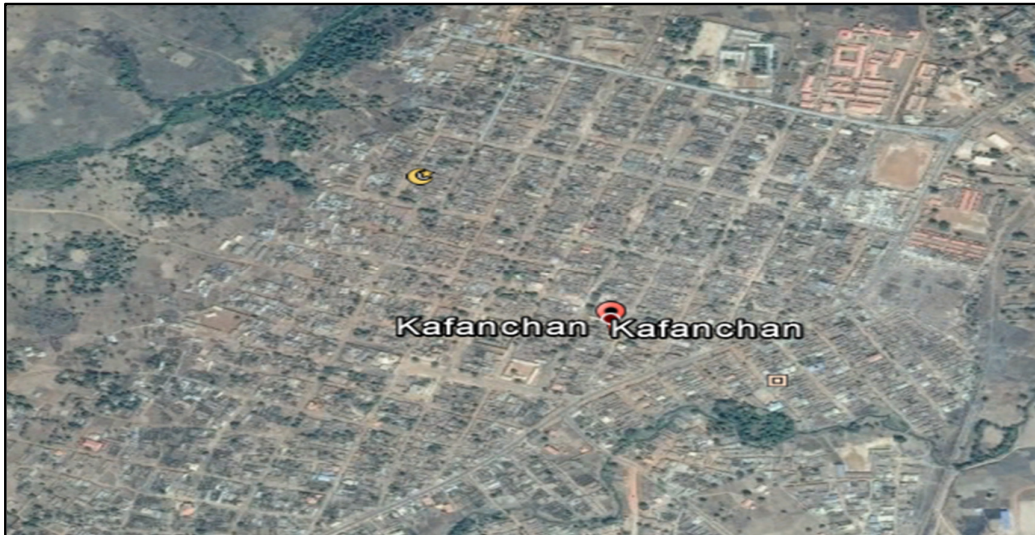

Fig. 1. Image of Kafanchan Physical Planning, Source: Google Earth [25]

3. Methodology

This study uses the experimental methodology. The research procedures are illustrated in Figure 2.

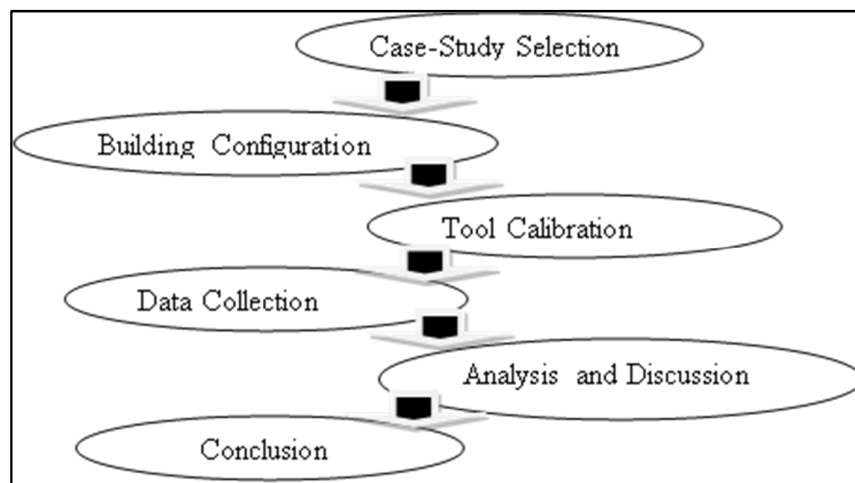

Fig. 2. Research Methodological Procedure

3.1 Case-Study Selection

The selection of the case-study buildings was a difficult task as we have to choose buildings with similar characteristics in order to establish the basis for comparison. Out of the several residential buildings in Kafanchan, two were selected –the fully enclosed courtyard residential building and the non-courtyard residential building. These buildings were selected and studied concurrently from the morning hours to evening (6:00 am to 6:00 pm) along with the outdoor (outside) area as a benchmark. The residential buildings were selected based on the following characteristics; the orientation of the buildings should be the same such that the longest view is facing the North/South, the rooms should be of equal dimensions and proportions, the material finish of the walls, floors,

ceiling, and roof should be of the same type. Even the material composition of doors and windows, their locations should also be the same.

3.2 Configuration of the Buildings

The configuration and characteristics of the selected buildings are illustrated in Figures 3 and 4, and Table 1.

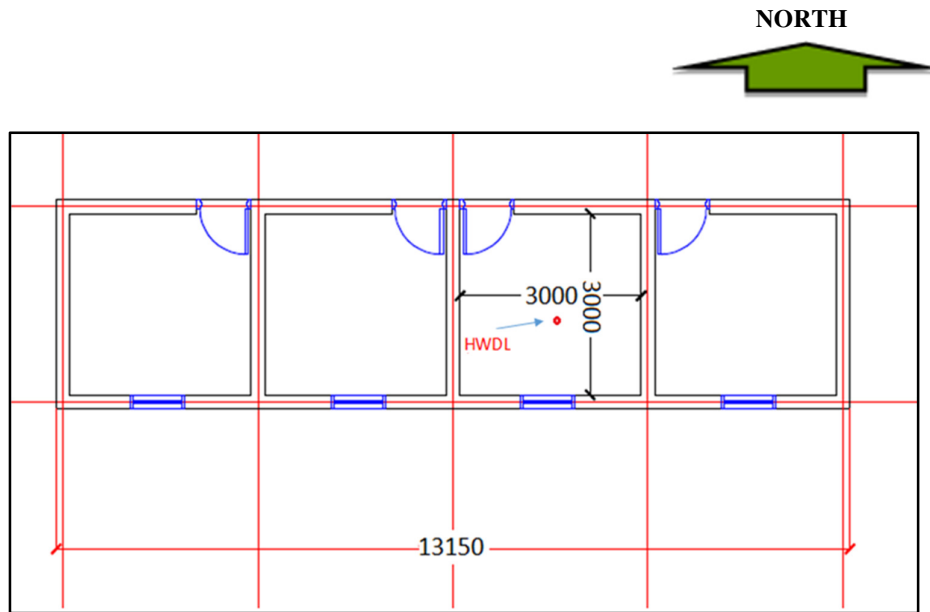

Fig. 3. Floor Plan of the Non-Courtyard House (Case-study 1)

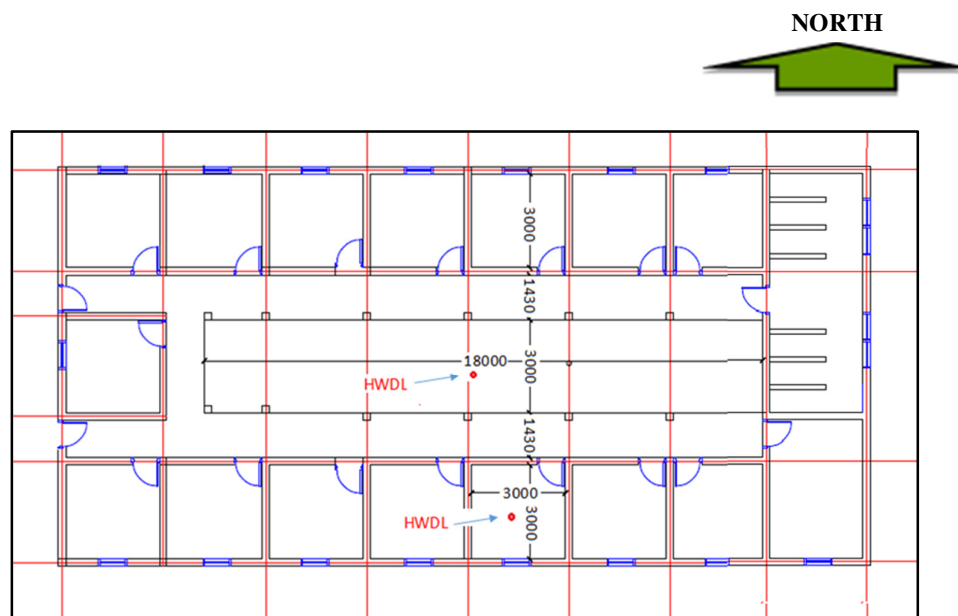

Fig. 4. Floor Plan of the fully enclosed Courtyard House (Case-study 2)

Table 1
 Characteristic of the Selected Buildings (Case-Study)

House-Type	Area of room	Orientation, Door, and Windows locations	Building Materials Finishes
Fully enclosed Courtyard House	3 x 3 = 9 m ²	North/South, Doors facing North, and windows facing south	-Iron Corrugated roofing sheets -Steel Frame Doors and Windows -PVC Ceiling Sheets -Sand/Cement Plastered Wall -Sand/Cement Screed Floor Finish
Non-Courtyard House	3 x 3 = 9 m ²	North/South, Doors facing North, and windows facing south	-Iron Corrugated roofing sheets -Steel Frame Doors and Windows -PVC Ceiling Sheets -Sand/Cement Plastered Wall -Sand/Cement Screed Floor Finish

3.3 Tool Calibration

Earlier before the beginning of the site experimentation, a calibration study was done to equate the results of the three hobo weather data loggers (HWDL) used. The calibration was conducted for the purpose of checking for precision in other to confirm their degree of accuracy. This procedure has concord with Leng [26] which stressed that the procedure is necessary. Therefore, the climatic variables used are; the air temperature and relative humidity. Figure 5 is a pictorial view of the three HWDL used during the experiment.



Fig. 5. A View of the Hobo Weather Data Loggers (HWDL)

3.4 Data Collection

This investigational study was directed to observe the microclimatic conditions of two different existing residential buildings with a prototype room characteristics and conditions. The case-study buildings are located in Kafanchan-Kaduna North Central Nigeria. Three hobo weather data loggers (HWDL) were used to collect data in the buildings, and the third one was used as a benchmark. The calibrated procedure was conducted a day before the measurement in order to certify the accuracy of the tools. The measurement took place instantaneously at the two rooms between 6.00am and

6.00pm on Tuesday, 29th day of April 2017. The selection of the date is due to the fact that date is close to summer equinox, and during such period of the year the sun is directly perpendicular to the equator and the solar radiation is always very high. Thus, the 29th day of April 2017 falls within the worst climatic conditions.

The tools were placed at the center of each room as illustrated in Figure 6 with opened doors and windows in other to determine the impact of the climatic variables (air temperature and relative humidity), and the air temperature and the relative humidity were measured at 30 minutes time intervals and recorded at a distance of 1,200 mm above the ground level. Then, the acquired data was read out through the HoboPro software and thereafter exported to Origin7.0 for analysis. Figure 6 and 7 are the pictorial view of the HWDL during the experiment and the two case-study.



Fig. 6. A View of HWDL in the Room



Fig. 7. A View of the Two Case-Study

4. Results and Discussion

Two different residential buildings have been measured to compare their microclimate performances. Two climatic variables namely; air temperature, and relative humidity were examined in the buildings, with the outdoor as a benchmark. Prior to the start of the examinations, the three HWDL were calibrated to confirm their accuracy. The following subdivisions consist of the findings and discussion of the experimental study.

4.1 Calibration of Tools HWDL

The calibration of the hobo weather data loggers (HWDL) was done for the three tools. The calibration result shows that there is a difference in air temperature and relative humidity values of 0.01°C to 0.02°C, and 0.01% to 0.03% respectively (see Figure 8 and 9). And according to [26], a difference of 0.01°C, 0.02°C, and 0.03% are very negligible in a study of this kind. Consequently, these findings have verified the soundness of the Hobo Weather Data Loggers for further experimental studies.

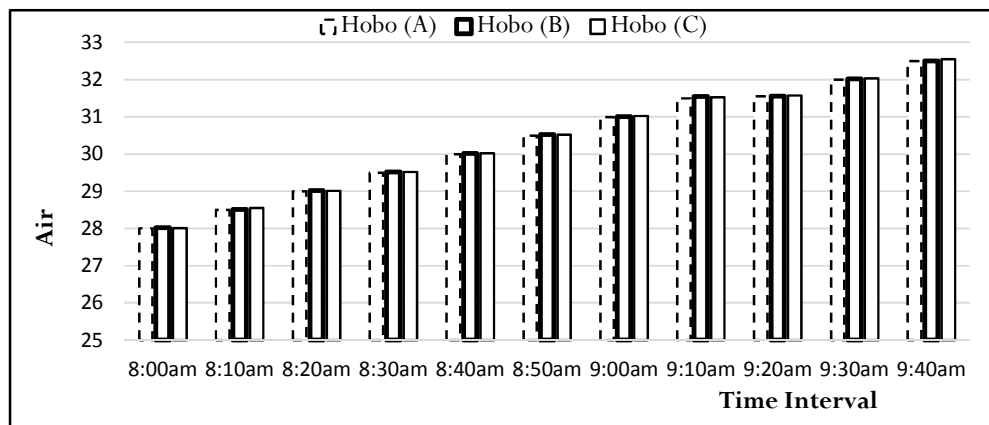

Fig. 8. Air Temperature of the three HWDL

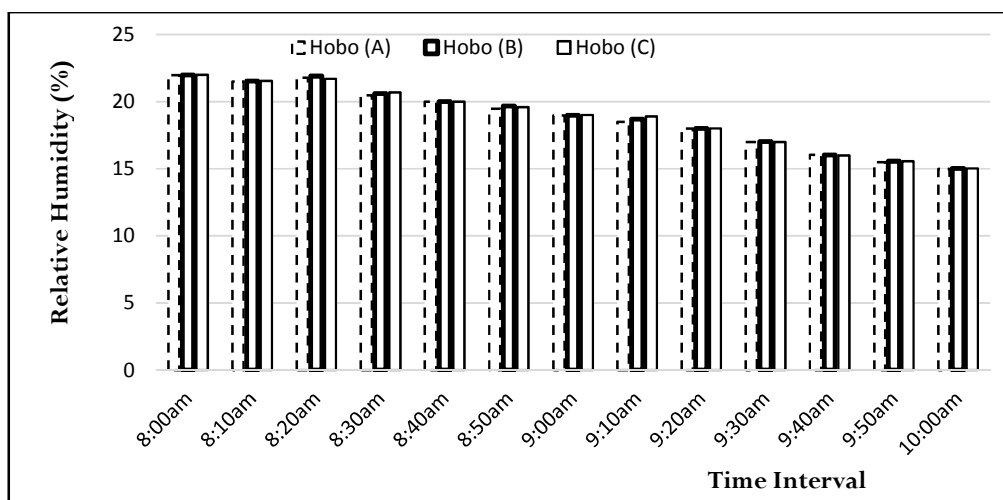

Fig. 9. Relative Humidity of the three HWDL

4.2 Site Measurements

4.2.1. Air temperature

The air temperature and the relative humidity in the two case-study were compared with the overall outdoor (benchmark). As revealed in Figure 10, the air temperature inside the fully enclosed courtyard residential building is much lower at all the different time intervals, ranging between 1°C to 4°C difference as compared to the non-courtyard building and the outdoor (benchmark) air temperature. Furthermore, the fully enclosed courtyard residential building has a much better air temperature than the non-courtyard residential building. The maximum variance of air temperature between the fully enclosed courtyard residential building and the non-courtyard residential building were 3°C recorded virtually consistently at all the different time interval. While, the minimum variance of air temperature was 2°C, recorded between 8:00 am to 11:00 am. This result concord with the opinion of Tablada [2] that the courtyard promotes efficient natural ventilation in buildings. Apart from the ventilation impact, the natural daylighting potentials of the courtyard might have contributed to the low air temperature due to the efficient natural daylighting penetration in the interior space of the building and thereby reducing the effect of heat generated by other electrical appliances.

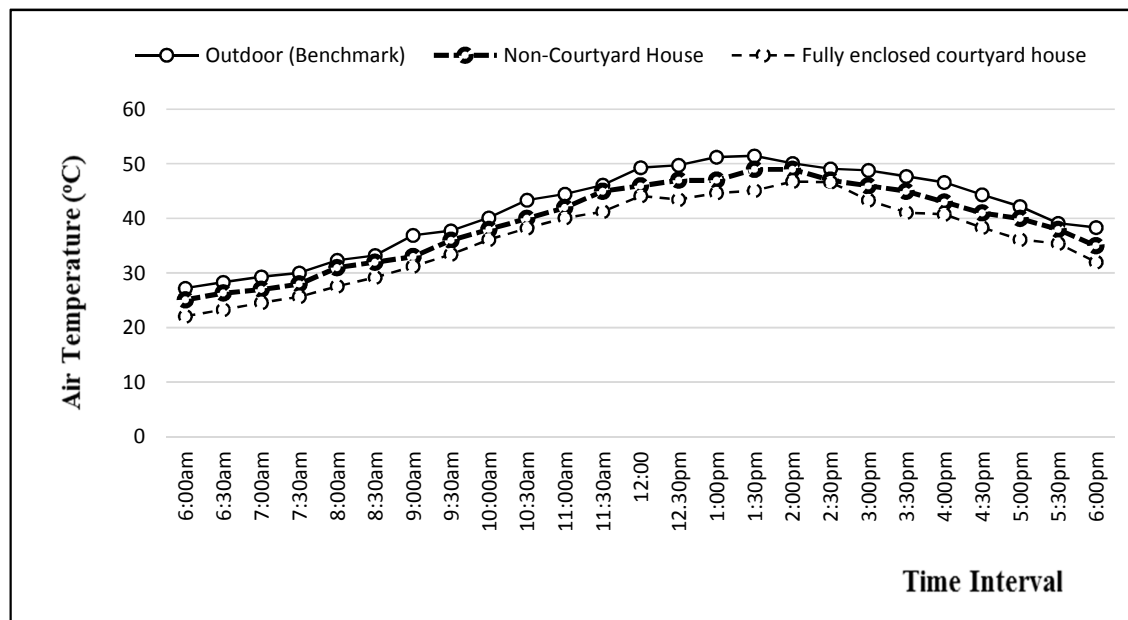

Fig. 10. Air Temperature

The fully enclosed courtyard residential building is fully bounded and has the advantage of contributing meaningfully to its own microclimate, whereas the non-courtyard residential building is not fully enclosed but exposed completely in all directions to the hot outdoor air temperature which does not favor microclimate modification [27]. Thus, according to Abdulbasit [28], the courtyard in the building may have affected the microclimatic performance of the residential building positively. However, a further investigational study is required in other to compare the microclimatic performance of the fully enclosed and the semi-enclosed courtyard buildings as opined by [5]. Meir [5] observed in his study that the two classifications of the courtyard, the fully enclosed and the semi-enclosed courtyard behaves differently under different climatic regions. The study was conducted in the hot-dry climatic region and it was concluded the semi-enclosed courtyard residential building can

perform better than the fully enclosed courtyard residential building provided that the impact of the building orientation is not ignored. This study has agreed with the fact that the courtyard can better the microclimatic performance of the building as revealed in the literature, but further studies can help to appraise this study.

4.2.2 Relative humidity

The second objective of this study is to investigate the relative humidity of the two typologies of buildings. The study revealed that the relative humidity had an inverse relationship with the air temperature, as the air temperature increases the relative humidity decreases. As illustrated in Figure 11, the relative humidity was greater in the outdoor benchmark (environment). The fully enclosed courtyard residential building has shown a much comfortable relative humidity readings than the non-courtyard residential building. The maximum variance of relative humidity between the two case-study was 10 % recorded at 6:30 to 9:30 am.

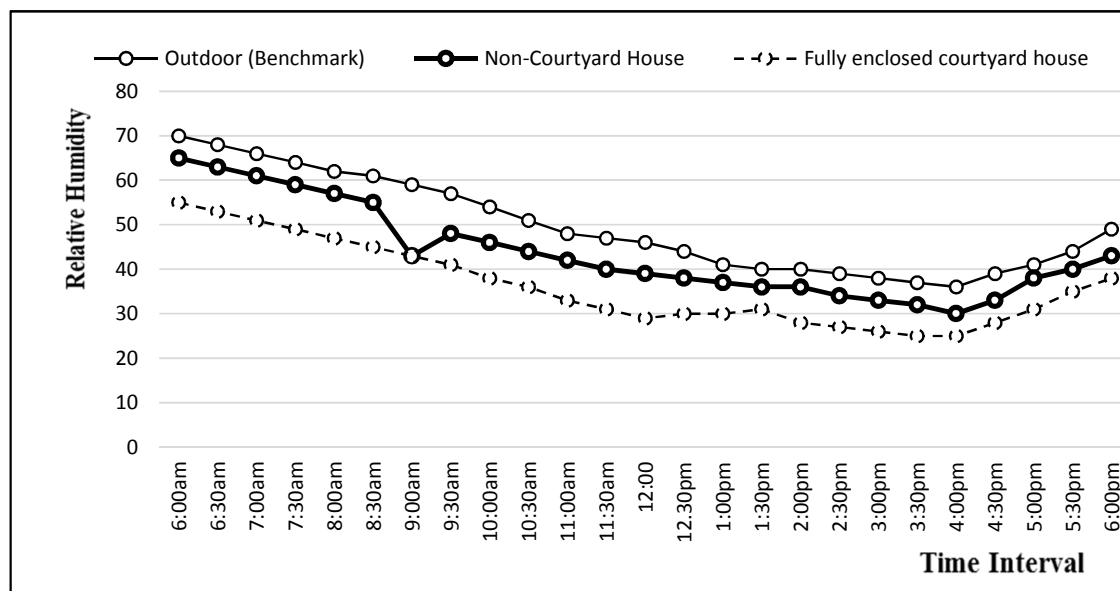

Fig. 11. Relative Humidity

Whereas, the minimum variance of the relative humidity was 5 % recorded at 4:00 pm to 6:00 pm. The non-courtyard residential building has a direct contact with the surrounding microclimate than the fully enclosed courtyard residential building. The degree of the exposure of a building is proportional to the amount of relative humidity received [7]. Thus, the more the building exposure to the open air environment the greater the quantity of relative humidity. Consequently, the high amount of relative humidity in the non-courtyard residential building has concord with the Bekovic conclusion.

According to Muhaisen [17], the thermal distress in the courtyard buildings is determined by the climatic factors such as air temperature and relative humidity. And the impact of these climatic elements on the building will tend to increase or decrease pending to the courtyard's geometry and the orientation. Therefore, the nature of the courtyard configuration might contribute to low relative humidity performance. Furthermore, the relative humidity may be due to some factors such as the climate of the study area, the absence water bodies, ponds and vegetation [23]. Chandler [20] discovered that the central courtyard with the appropriate physical and natural parameters could aid

the effectiveness of the courtyard to act as a passive cooling element in the building. Consequently, the absence of the physical and natural parameters has worsened the microclimatic performance of the studied courtyards residential building, and presence of such could have better both their courtyard (space) performances and even their indoor (interior of the building space) thermal performances.

5. Conclusion

The main objective of this study is to compare the microclimatic performances of the courtyard and the non-courtyard residential building in order to draw a conclusion on the best option. The courtyard residential building has confirmed a more favorable microclimatic performance than the non-courtyard and therefore, this study can be concluded as follows:

- (1) The fully enclosed residential courtyard building performs better than the non-courtyard residential building with a different range of 0°C to 3°C, and 5 % to 10% for air temperature and relative humidity respectively. And so, a further simulation study on its optimum ratio for a better environmental performance should be investigated.
- (2) The outdoor space (benchmark) is the poorest scenario, followed by the non-courtyard house, and then the fully enclosed courtyard house. The air temperature and relative humidity difference are between 1°C to 4°C, and 3% to 7% respectively. Consequently, it can be concluded that the courtyard is a good passive architectural design element in the hot-dry climate of Nigeria.

In conclusion, the courtyard residential building has confirmed to be better than the non-courtyard residential building. However, the investigation of multiple courtyard and non-courtyard residential buildings due to the difficulty in selecting case-studies, and the lack of hobo weather data logger tools has hindered a comprehensive appraisal of the study. Therefore, further simulation studies to validate the findings of this study is recommended. And the professional architects should endeavor to adopt the use of the simulation tool in their architectural design due to its contribution to the realization energy efficient architectural building delivery.

Acknowledgement

This research effort is part of an ongoing Ph.D. study on "Courtyard Optimum Ratio and Orientation for Indoor Microclimatic Performance of Fully Enclosed Courtyard Residential Buildings". The authors wish to acknowledge the Kaduna State University, Nigeria, the Nigerian Tertiary Education Trust Fund (TETFund) and Universiti Teknologi Malaysia for aiding this research.

References

- [1] Intergovernmental Panel on Climate Change. *Climate change 2014: mitigation of climate change*. Vol. 3. Cambridge University Press, 2015.
- [2] Tablada, Abel, Bert Blocken, Jan Carmeliet, Frank De Troyer, and Han Verschure. "The influence of courtyard geometry on air flow and thermal comfort: CFD and thermal comfort simulations." In *Proceedings of 22nd conference on passive and low energy architecture*, vol. 1, pp. 75-80. 2005.
- [3] Akande, O. K. "Passive design strategies for residential buildings in a hot dry climate in Nigeria." *WIT Transactions on Ecology and the Environment* 128 (2010): 61-71.
- [4] Muhaisen, Ahmed S., and Mohamed B. Gadi. "Effect of courtyard proportions on solar heat gain and energy requirement in the temperate climate of Rome." *Building and Environment* 41, no. 3 (2006): 245-253.
- [5] Meir, Isaac A., David Pearlmutter, and Yair Etzion. "On the microclimatic behavior of two semi-enclosed attached courtyards in a hot dry region." *Building and Environment* 30, no. 4 (1995): 563-572.

- [6] Al-Hemiddi, Nasser A., and Khalid A. Megren Al-Saud. "The effect of a ventilated interior courtyard on the thermal performance of a house in a hot-arid region." *Renewable Energy* 24, no. 3 (2001): 581-595.
- [7] Berkovic, Sigalit, Abraham Yezioro, and Arieh Bitan. "Study of thermal comfort in courtyards in a hot arid climate." *Solar Energy* 86, no. 5 (2012): 1173-1186.
- [8] Weihe, W. H. "Life expectancy in tropical climates and urbanization." In *Life expectancy in tropical climates and urbanization*. 1984.
- [9] Bulus, Markus, Malsiah Hamid, and Yaik Wah Lim. "Courtyard as a Passive Cooling Strategy in Buildings." *International Journal of Built Environment and Sustainability* 4, no. 1 (2017).
- [10] Abass, Fatma, Lokman Hakim Ismail, and Mohmed Solla. "A review of courtyard house: history evolution forms, and functions." (2006).
- [11] Lea, D., and Runcie, M. (Eds.). New York: Oxford UP, USA, 2002
- [12] Oke, Tim R. "Canyon geometry and the nocturnal urban heat island: comparison of scale model and field observations." *International Journal of Climatology* 1, no. 3 (1981): 237-254.
- [13] Yang, Xinyan, Yuguo Li, and Lina Yang. "Predicting and understanding temporal 3D exterior surface temperature distribution in an ideal courtyard." *Building and Environment* 57 (2012): 38-48.
- [14] Markus, B. "Review of Courtyard House in Nigeria: definitions, history, evolution, typology, and functions." *AFRREV STECH: An International Journal of Science and Technology* 5, no. 2 (2016): 103-117.
- [15] Meir, I. A., Etzion, I and D. Faiman. Energy>> *Aspects of Design in Arid Zones*, Desert Architecture Unit/Applied Solar Calculations Unit, J. Blaustein Institute for Desert Research, Ben Gurion University of the Negev, Sede Boqer Campus & State of Israel, Ministry of Energy and Infrastructure, Research and Development Division, Jerusalem, 1990.
- [16] Markus, B. "A review on courtyard design criteria in different climatic zones." *African Research Review* 10, no. 5 (2016): 181-192.
- [17] Muhaisen, Ahmed S., and Mohamed B. Gadi. "Effect of courtyard proportions on solar heat gain and energy requirement in the temperate climate of Rome." *Building and Environment* 41, no. 3 (2006): 245-253.
- [18] Muhaisen, Ahmed S., and Mohamed B. Gadi. "Shading performance of polygonal courtyard forms." *Building and Environment* 41, no. 8 (2006): 1050-1059.
- [19] Oke, Tim R. "Canyon geometry and the nocturnal urban heat island: comparison of scale model and field observations." *International Journal of Climatology* 1, no. 3 (1981): 237-254.
- [20] Chen, Ming Dong. "Optimization design of courtyard sunspace passive solar house." In *Applied Mechanics and Materials*, vol. 178, pp. 33-36. Trans Tech Publications, 2012.
- [21] Bulus, Markus. "EVALUATION OF COURTYARD USAGE AND ITS DESIGN REQUIREMENTS IN RESIDENTIAL BUILDINGS IN NIGERIAN HOT-DRY CLIMATE."
- [22] Daroda, Kabiru S. "Climate responsive architecture: Creating greater design awareness among architects." *Journal of Environmental Issues and Agriculture in Developing Countries* 3, no. 1 (2011): 33.
- [23] Bureau of Land and Survey Kaduna [BLSK]. Map of Kaduna State Showing the Local Government Areas, 2010.
- [24] Yunana, M A., Siaka, S., Nale, B. Y., Simon, S., & Markus, B. Analysis of Bush Burning in the Northern Guinea Savannah of Kaduna State: Implications for Agriculture and the Environment. *International Journal of Comparative Studies in International Relations and Development*, Vol 3 No 1 (2014): 2354-4298.
- [25] Google Earth. Retrieved on the 23/08/2017 from <http://earthviewmaps.com/>
- [26] Leng, P. C., M. H. Ahmad, Dilshan Remaz Ossen, and Malsiah Hamid. "Investigation of integrated environmental solutions-virtual environment software accuracy for air temperature and relative humidity of the test room simulations." In *UMT 11th International Annual Symposium on Sustainability Science and Management*, pp. 1298-1305. 2012.
- [27] Aldawoud, Abdelsalam. "Thermal performance of courtyard buildings." *Energy and Buildings* 40, no. 5 (2008): 906-910.
- [28] Almhafdy, Abdulbasit, Norhati Ibrahim, and Sabarinah Sh Ahmad. "Courtyard As a Microclimatic Modifier Experimental Study on Actual Site Abdulbasit Almhafdy1, Norhati Ibrahim2, b, Sabarinah Sh Ahmad3, c, Wan Mohd. Naim Wan Salleh4, d." (2014).