

## Circuit for early lightning warning alarm system

Noor Azlinda Ahmad<sup>1,\*</sup>, Zawani Amirah Rasid<sup>1</sup>, Zuraimy Adzis<sup>1</sup>

<sup>1</sup> Institute of High Voltage & High Current (IVAT), Faculty of Electrical Engineering Universiti Teknologi Malaysia, 81310 Skudai Johor, Malaysia

### ARTICLE INFO

#### Article history:

Received 11 May 2017

Received in revised form 5 June 2017

Accepted 3 July 2017

Available online 9 August 2017

#### Keywords:

Lightning, warning system, lightning  
safety

### ABSTRACT

Lightning is among the most deadly natural phenomena to mankind. This phenomenon is seen to increase globally as well as in Malaysia. Lightning does strike open areas such as playing fields and playgrounds and these areas are places people gather. Sensors that can detect the early occurrence of lightning have been developed for detecting approaching lightning activity in this project. The main objective is to provide early lightning warning system to the public and hence to reduce the number of fatalities due to lightning strike. The warning circuit was designed and simulated using Multism11. Basic operational method of the circuit is based on the comparative voltage method using LM339N integrated circuit comparator (IC). Light Emitting Diodes (LEDs) were used as indicators to indicate if the incoming voltage level is higher or lower than that of the safety level.

Copyright © 2017 PENERBIT AKADEMIA BARU - All rights reserved

## 1. Introduction

Lightning is one of the most formidable natural phenomena in the world. It can lead to adverse effects either to properties or human if precautions are not taken. With an extremely high current, high voltage and transient electric discharge, it can bring injuries or even fatality to human. Although hundreds survive from lightning strike, once get struck, they will suffer from a variety of lasting symptoms such as ophthalmic and otology effects (eyeball and hearing problems) [1]. Further, stroke current can also damage the cardiovascular, central nervous, dermatologic and musculoskeletal systems [2].

Countries lying close to the equator such as Malaysia experience high distribution of lightning and thunderstorm activities. The average number of thunderstorm days (a day where thunder is heard at the station which signifies the presence of a nearby thunderstorm) in Malaysia is 200 days as reported by Malaysian Meteorological Department (MMD) [3] with the highest mean annual thunderstorm days ever recorded is 316 (until 2015) at KLIA, Sepang [4]. Higher atmospheric humidity, global warming, solar activity and land topography including land clearing for development are some of the factors that contribute to the increasing number of lightning in Malaysia [4]. In addition, it was reported that the effects of lightning on communication / system network account

\* Corresponding author.

E-mail address: Noor Azlinda Ahmad ([noorazlinda@utm.my](mailto:noorazlinda@utm.my))

for equipment damage, data losses and malfunctioning of control and automated system that may cost over RM 250 million and thousands of human injuries and death [5]. Lightning incident occurred mostly over open areas compared to over the sea. This fact is consistent with the data from earth-orbiting satellites where it showed that, on average, around 80% of lightning flashes occur over land while the rest is over the ocean [6]. On the other hand, lightning initiates many forest fires, and over 30 % of all electric power line failures are lightning related. Further, each commercial aircraft is struck by lightning on average once a year [7]. Figure 1 illustrates the locations of lightning incident in Malaysia from 2009 till 2011.

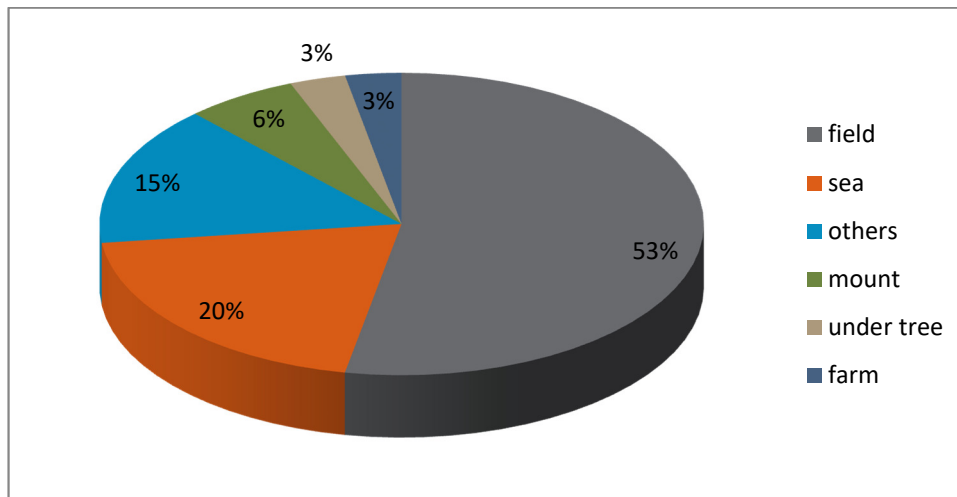

**Fig. 1.** Locations of lightning incident in Malaysia from 2009 to 2011 (adapted from [8]).

The increase of lightning incidents in Malaysia is partly due to lack of lightning safety awareness. Outdoor activities still continue in drizzling rain with thunder. Some even took shelter under trees where those places are more vulnerable to lightning. Due to the fatal effect of lightning, many lightning warning system have been established in order to reduce or avoid losses due to lightning. Tao *et al.* [9] reported the small-scale and short-time lightning warning method based on atmospheric electric field and trend prediction of Lightning Locating System (LLS). The effectiveness and practicality of the two methods were investigated by applying to transmission line in China power grid. Another study [10] reported the lightning early system based on cloud computing technology. This technology is effective and can solve the traditional standalone computing problems, such as the low efficiency and slow speed of data process. Meanwhile, a systematic monitoring of the status and trends of the thunderstorm activity of a given region to minimize damage from lightning has been investigated by Serkov *et al.* [11]. In their study, problem of optimal synthesis of an early warning system of thunderstorm hazards has been resolved where the inter-cloud discharge registration and identification allows the time interval of 10 minutes before the first dangerous discharge "cloud-to-ground". Based on their result, it is possible to implement an early warning system on storm hazard.

As a warning of occurrence of lighting activities, the circuit for early lighting detection system with alarm is designed in this study and the results are shown and discussed. It is hoped that the outcome of this project will benefit the public hence drastically reduce the number of lightning injuries and fatalities in Malaysia.

## 2. Methodology

### 2.1 Development of Circuit

*Multism*<sup>TM</sup> 11.0 simulation software was used in designing and testing the alarm circuit as depicted in Figure 2. The design begins with evaluating the type of input for the lightning detector and type of output signal to be used in the detection system. The input of the alarm circuit must be in DC form, since the measured output from the buffer amplifier is in DC voltage [14]. A Comparator IC LM339N is used to compare the input signal to the threshold value since both of its input and output are in DC.

For practical reasons, the saturation voltage for the comparator was set to be +12 V and 0 V. Since the output for this IC is an open collector, so a 100 kΩ resistor is connected between the supply and the output of comparator for external pull up or else the output value cannot be increased. The comparator also drive low saturation voltage which consequently affect devices connected to the output of this comparator. Two types of relays are used to control the output. An NPN BJT type BC547C is used to control the relay whether it should function from normally open (NO) to normally closed (NC) or vice versa.

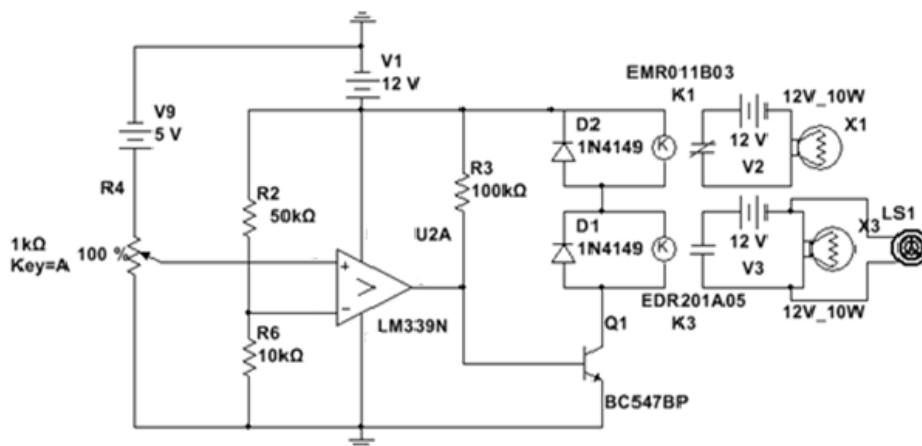

R4 – Potentiometer; K1 – Normally close contact; K3 –Normally open contact; X1 – Green colour of indicator; X3 –Red colour of indicator; LS1 – Alarm

**Fig. 2.** A diagram of circuit connection for the alarm system

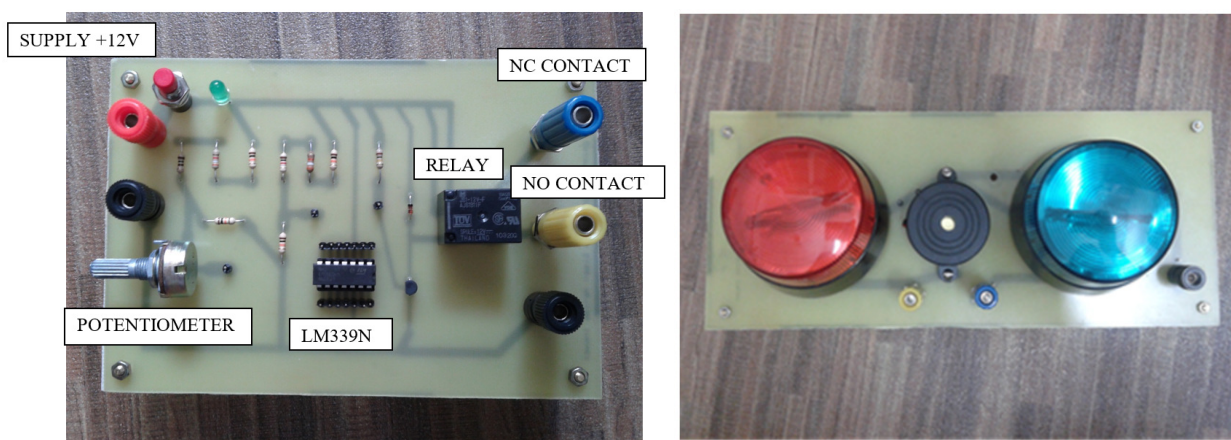

**Fig. 3.** Connection of alarm circuit on the PCB board (left) and types of indicators used in the circuit (right)

The collector of transistor is connected to the relay while the base of the transistor is placed at the end of the output comparator. This will establish necessary current to energize relay in the collector circuit. The relay current depends on the base current of transistor controlled by the output from the comparator. A 1N4149 diode is connected in parallel to protect the BJT. This can be done by blocking the discharge current from the coil of contactor from flowing back to the transistor. The complete diagram of circuit connection is shown in Figure 3.

Two types of light indicator; green and red were used to indicate the safety situation. Red color indicates unsafe situation while green color indicates the opposite situation. Simultaneously, a siren used in the circuit will function as soon as the red indicator turns on. Voltage supply for this circuit is 12 Volts to demonstrate the field intensity from lightning. This is because, from previous studies, the voltage measured from lightning electric field measurement was in the range of 1 to about 20 V [12, 13]. Meanwhile 2 Volts is set as a trigger level to notify the higher possibility of strike to occur. This value is determined based on the value suggested by [14] and is calculated based on the following equation

$$V_2 = \frac{R_6}{R_2 + R_6} = \frac{10k\Omega}{(10 + 50)k\Omega} = 2V \tag{1}$$

**Table 1**

The range of the input voltage with colour of indicator

Range for input voltage (V+), V	Colour of indicator
< 2 V	Green
>2 V	Red

- Alarm will be turned on as long as the red indicator turned on

In this circuit, the NO contact is connected to the red indicator while the NC contact is connected to the green indicator. Proper threshold value must be set to make sure the circuit functions. When the input voltage (V+) is greater than the reference voltage (V-), the output of the comparator would be +12 V. This causes current to flow through the base of the BJT and finally its collector current also flows through the coil. The coil of relay will be energized and causes the common part to be activated by changing it from the NO contact to the NC contact. This will finally light up the red indicator as illustrated in Figure 4.

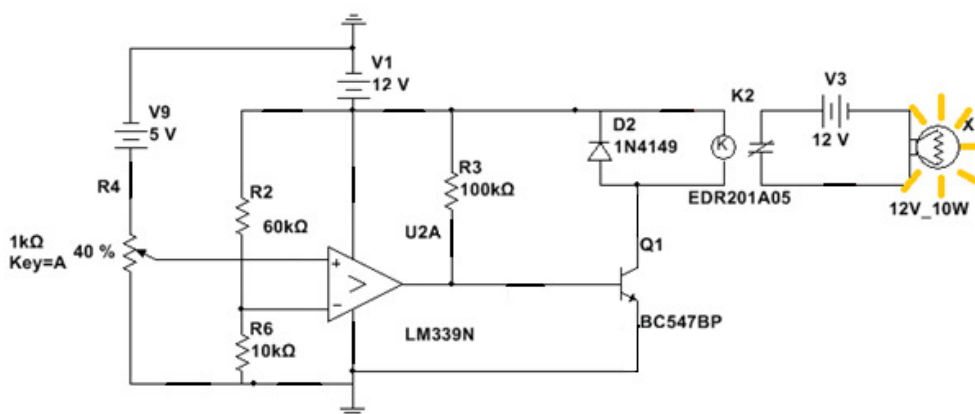

**Fig. 4.** The current flow when input voltage is greater than reference voltage

However, when the input voltage (V+) is less than reference voltage (V-), the output of the comparator will be 0 Volts. No current is flowing through the base of the transistor as well as at its collector. Hence, the coil of the relay will discharge and causes the common part to be turned back at its previous condition and turn on the green indicator as illustrated in Figure 5.

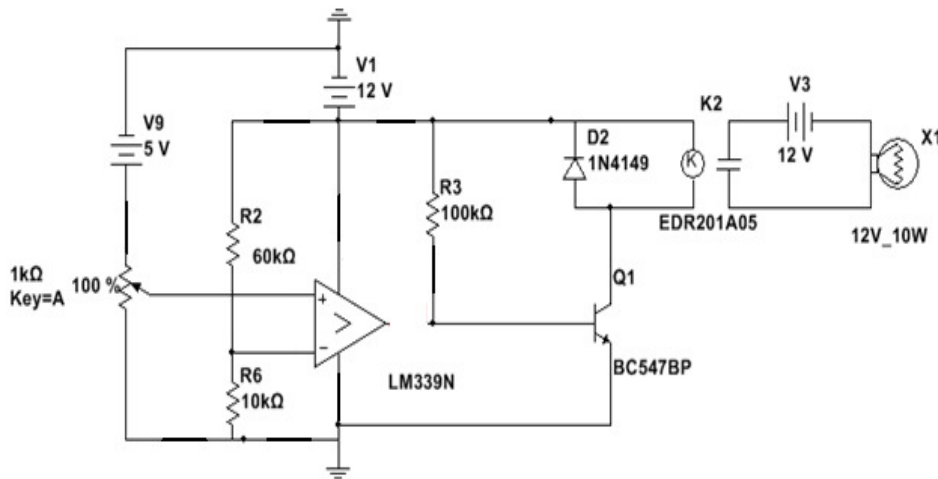

Fig. 5. The current flow when input voltage is less than reference voltage

The concept of lightning warning system is based on lightning detection method which relies on the presence of an electric field in the atmosphere. In normal fair weather, the electric field is normally 100-200 V/m but this value may increase to as much as four order of magnitude (up to 2000 V/m or above) during thunderstorm [14, 15, 16] which indicates higher chances of lightning. Note that in this study, we are only focusing on the development of alarm circuit and no real measurement was done to verify the field intensity value as indicated in Table 2 below. These two values are only used as guideline in this study to indicate the safety condition during thunderstorm.

**Table 2**  
 Threshold value for the indicators [12]

Indicator	Field intensity Threshold	Safety status
Green light	Less than 2000 V/ m	Safe
Red light and siren	Above 2000 V/m	Unsafe

A complete flowchart which simplified the whole process of circuit design in this study is illustrated in Figure 6.

### 3. Results and Discussion

The experimental result and circuit simulation are presented in this section. Their relevant information such as the output voltage and flowing of current from the output of comparator through the base of the transistor for both conditions (simulation and experiment) were recorded in a separate table for each type of connection.

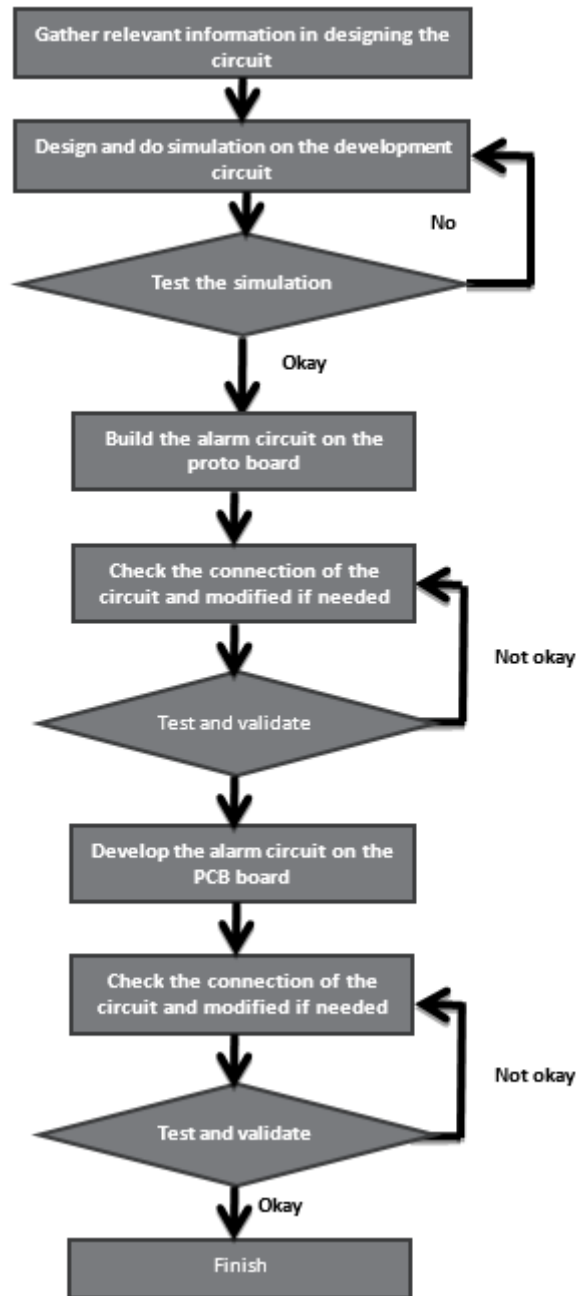

**Fig. 6.** Flowchart which describes the whole process of this research work

### 3.1 Simulation Result

The complete design for the alarm circuit as shown in Figure 2 was simulated using *Multism<sup>TM</sup>11*. Only the input ( $V^+$ ), reference ( $V^-$ ) and output voltage ( $V_o$ ) of each comparator were simulated. Results of simulation are tabulated in Table 3 and 4 while the wave curve of input, output and reference voltage are depicted in Figure 7 and 8 for  $V^+ > V^-$  and  $V^+ < V^-$ , respectively.

**Table 3**  
 Simulation result when  $V^+ > V^-$

$V^+$ (V)	$V^-$ (V)	$V_O$ (V)	$I_B$ (mA)	$I_C$ (A)	Colour of indicator to be light on	Alarm
1.5	0	0.714	0.112	0.012	Red	On
3	0	0.714	0.112	0.012	Red	On
9	0	0.714	0.112	0.012	Red	On
12	0	0.714	0.112	0.012	Red	On
3	1.5	0.714	0.112	0.012	Red	On
9	1.5	0.714	0.112	0.012	Red	On
12	1.5	0.714	0.112	0.012	Red	On
9	3	0.714	0.112	0.012	Red	On
12	3	0.714	0.112	0.012	Red	On
12	9	0.714	0.112	0.012	Red	On

**Table 4**  
 Simulation result when  $V^+ < V^-$

$V^+$ (V)	$V^-$ (V)	$V_O$ (V)	$I_B$ (A)	$I_C$ (A)	Colour of indicator to be light on	Alarm
1.5	0	0.013	0	0	Green	Off
3	0	0.013	0	0	Green	Off
9	0	0.013	0	0	Green	Off
12	0	0.013	0	0	Green	Off
3	1.5	0.013	0	0	Green	Off
9	1.5	0.013	0	0	Green	Off
12	1.5	0.013	0	0	Green	Off
9	3	0.013	0	0	Green	Off
12	3	0.013	0	0	Green	Off
12	9	0.013	0	0	Green	Off

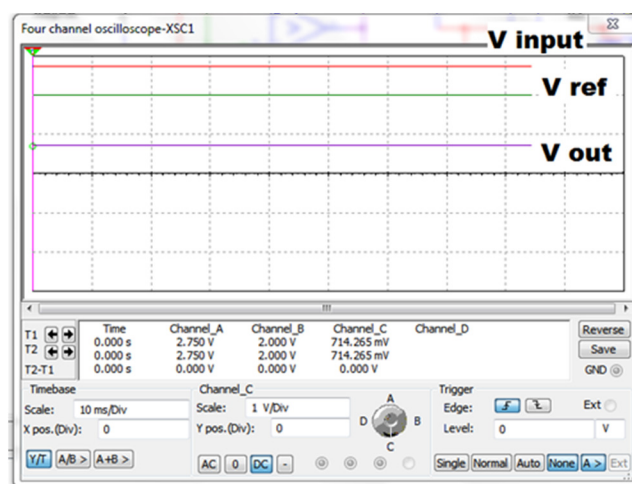

**Fig. 7.** Waveform of the input, output and reference voltage when  $V^+ > V^-$

In this simulation exercise, the reference voltage is fixed and the value is within 1.984 – 1.985 Volts. The input voltage can be varied by changing the potentiometer. Based on the simulation results, the value of output voltage depends on the comparator output averaging at 0.714 Volts and 0.013 Volts for  $V^+ > V^-$  and  $V^+ < V^-$ , respectively.

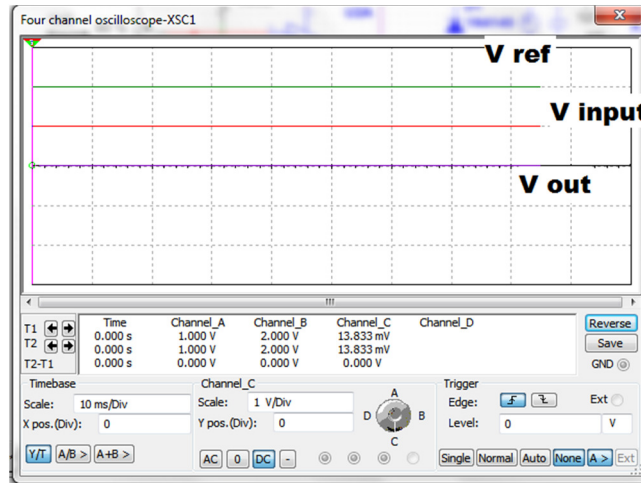

**Fig. 8.** Waveform of the input, output and reference voltage when  $V^+ < V^-$

### 3.2 Experimental result

All electronic components are arranged according to the simulation circuit as shown previously in Figure 3 and has been tested in the laboratory. The potential and reference voltage were determined prior to conducting the experiment. It was recorded that the potential and reference voltage are 4.77 V and 1.98 V, respectively. These two values are slightly lower than the actual value (5 V and 2 V) which perhaps, could be due to losses in circuit connection. Since multi meter cannot be connected in series between the output of the comparator and the base of the transistor, therefore a 1  $\Omega$  shunting resistor is connected in series between the output of the comparator and the base of the transistor. Then, the voltage drop across the resistor is measured using volt meter. Based on the measurement result, it was observed that the value of output voltage is depending on the comparator output varies between 0.750 to 0.753 V and 0.012 to 0.013 V for  $V^+ > V^-$  and  $V^+ < V^-$ , respectively.

**Table 5**  
 Experimental result of the alarm circuit when  $V^+ > V^-$

$V^+(7)$ , V	$V^-(6)$ , V	$V_o(1)$ , V	Colour of indicator to be light on	Alarm
4.734	1.9843	0.754	Red	On
4.201	1.9840	0.754	Red	On
4.571	1.9840	0.754	Red	On
3.954	1.9840	0.754	Red	On
3.49	1.9840	0.753	Red	On
3.21	1.9830	0.753	Red	On
2.93	1.9840	0.753	Red	On
2.67	1.9840	0.753	Red	On
2.34	1.9840	0.753	Red	On
2.03	1.9840	0.750	Red	On



Note that no base and collector current were recorded during the experiment since the aim of this study is only to test the validity of the circuit design and not measuring the current.

**Table 6**  
Experimental result of the alarm circuit when  $V^+ < V^-$

$V^+(7)$ , V	$V^-(6)$ , V	$V_o(1)$ , V	Colour of indicator to be light on	Alarm
1.887	1.9840	0.012	Green	Off
1.752	1.9840	0.013	Green	Off
1.650	1.9840	0.013	Green	Off
1.569	1.9840	0.012	Green	Off
1.576	1.9840	0.013	Green	Off
1.456	1.9840	0.013	Green	Off
1.305	1.9850	0.013	Green	Off
1.106	1.9840	0.013	Green	Off
0.846	1.9840	0.013	Green	Off
0.585	1.9850	0.013	Green	Off
0.240	1.9840	0.013	Green	Off
0	1.9840	0.013	Green	Off

#### 4. Conclusion

The alarm circuit for lightning warning system has been successfully designed and tested. It is shown that the circuit manage to function accordingly based on the desired situation and able to trigger alarm when a thunderstorm approaches. Therefore, it is expected that the outcome of this project will benefit the public in reducing the number of lightning injuries and fatalities in Malaysia. Some effort to incorporate the design to an actual lightning antenna system for real time measurement is not shown in this paper and the work is still in progress.

#### References

- [1] Hassan, M. K., RZ Abdul Rahman, A. Che Soh, and M. Z. A. Ab Kadir. "Lightning strike mapping for peninsular Malaysia using artificial intelligence techniques." *Journal of Theoretical and Applied Information Technology* 34, no. 2 (2011): 202-214.
- [2] Price T, Cooper MA: 'Electrical and Lightning Injuries', Rosen's Emergency Medicine, Concepts and Clinical Practices, 6th Edition, 2006.
- [3] Krider, E. Philip, R. Carl Noggle, and Martin A. Uman. "A gated, wideband magnetic direction finder for lightning return strokes." *Journal of Applied Meteorology* 15, no. 3 (1976): 301-306.
- [4] Abdullah, Noradlina, Mohd Pauzi Yahaya, and Nadiah Salwi Hudi. "Implementation and use of lightning detection network in Malaysia." In *Power and Energy Conference, 2008. PECon 2008. IEEE 2nd International*, pp. 383-386. IEEE, 2008.
- [5] Ab-Kadir, Mohd Zainal Abidin. "Lightning severity in Malaysia and some parameters of interest for engineering applications." *Thermal Science* 20, no. suppl. 2 (2016): 437-450.
- [6] Encyclopedia Britannica. Encyclopedia Britannica Online Academic Edition. "Thunderstorm electrification", <http://www.britannica.com>, Encyclopaedia Britannica Inc., 2012 Wed. 21 Dec, 2012.
- [7] Rakov, V. A. "Electromagnetic methods of lightning detection." *Surveys in Geophysics* 34, no. 6 (2013): 731-753.
- [8] Nur Najihah binti Abu Bakar. 'Lightning Fatalities in Malaysia'. Degree Thesis. Universiti Teknologi Malaysia; 2012.
- [9] Tao, Hantao, Shanqiang Gu, Haitao Wang, Wanxing Feng, Juntian Guo, Yu Wang, and Lei Zhang. "Method of lightning warning based on atmospheric electric field and lightning location data." In *Lightning Protection (ICLP), 2016 33rd International Conference on*, pp. 1-5. IEEE, 2016.
- [10] Ding, Zhihui, and Jianming Guo. "Design of Port Lightning Early Warning System Based on Cloud Technology." In *Industrial Informatics-Computing Technology, Intelligent Technology, Industrial Information Integration (ICIICIT), 2016 International Conference on*, pp. 214-217. IEEE, 2016.

- 
- [11] Serkov, Alexander, Sergei Nikitin, Vladimir Kravchenko, and Vladimir Knyazev. "Thunderstorm hazards early warning system." In *Problems of Infocommunications Science and Technology (PIC S&T), 2015 Second International Scientific-Practical Conference*, pp. 137-138. IEEE, 2015.
- [12] Baharudin, Zikri Abadi, Vernon Cooray, Mahbubur Rahman, Pasan Hettiarachchi, and Noor Azlinda Ahmad. "On the characteristics of positive lightning ground flashes in Sweden." *Journal of Atmospheric and Solar-Terrestrial Physics* 138 (2016): 106-111.
- [13] Wooi, Chin-Leong, Zulkurnain Abdul-Malek, Noor-Azlinda Ahmad, and Ali I. El Gayar. "Statistical analysis of electric field parameters for negative lightning in Malaysia." *Journal of Atmospheric and Solar-Terrestrial Physics* 146 (2016): 69-80.
- [14] Zakariah, Ahmad Shahrir Azwan. "Electronic Buffer for Vertical Electric Field Measurement (Radiation Components) from Lightning Return Stroke." PhD diss., Universiti Teknologi Malaysia, 2012.
- [15] EFM User's Guide, Theory of Operation: Electric Field Mill II. Arizona: Global Atmospheric, Inc., pp. 1-2., 2000.
- [16] Sidik, Muhammad Abu Bakar, Hamizah Binti Shahroom, Zainal Salam, Zokafle Buntat, Zainuddin Nawawi, Hussein Ahmad, and Yanuar Zulardiansyah Arief. "Lightning monitoring system for sustainable energy supply: A review." *Renewable and Sustainable Energy Reviews* 48 (2015): 710-725.