

Circuit design and development of contactless sensor system for finger tracking in piano playing

Open
Access

Choo Chee Wee ¹, Muralindran Mariappan ^{1,*}, Resot Iggau ¹, Brendan Khoo ¹, Wong Wei Kitt ¹

¹ Faculty of Engineering, Universiti Malaysia Sabah, 88400, Kota Kinabalu, Sabah, Malaysia

ARTICLE INFO

ABSTRACT

Article history:

Received 31 May 2016

Received in revised form 30 June 2016

Accepted 15 August 2016

Available online 19 December 2016

Piano technique is one of the main part of piano playing. Some researches had attempted to unveil the technique of virtuoso pianists using technologies. These researches employ different types of sensors in order to capture motion data of piano playing. However, one area in this research had been under-represented, which is finger position and pressure measurement applied by the musician while playing the musical instrument. Research that embark on this area faced a common problem, the sensors used in these research are directly in contact with the pianist, which causes a change of piano playing experience. Since piano playing consists of very delicate interaction between the pianist and the piano, such change of experience may affect the pianist's performance. These sensors are considered to be intrusive to the piano playing experience. Concluding the challenges faced by current technologies, a non-intrusive sensor is proposed and the circuit design of the sensor is discussed in this paper.

Keywords:

Pedagogy, Piano technique, Augmented instrument

Copyright © 2016 PENERBIT AKADEMIA BARU - All rights reserved

1. Introduction

Musician had been striving to perfect the technique of musical instrument playing for centuries. Along with advancements of technologies, a number of methods were developed to capture the movements of the musical instrument players in order to analyse their techniques. The mentioned technologies often fuse sensors with the musical instrument, creating augmented musical instruments. By definition, augmented musical instruments are created by the addition of sensors to existing acoustic or electric instruments [1]. These sensors collect various types of input from the musical instrument players, not only tracking the movement of the players, but also allowing them to control additional digital audio effects or sound synthesis processes through their gestures. These methods offer numerous possibilities for musical performance [2]. For these augmented instruments, one area had been underrepresented, which is finger position and pressure

* Corresponding author.

E-mail address: murali.myris@gmail.com (Muralindran Mariappan)

measurement, applied by the musician while playing the musical instrument [3]. The area of interest of this research is piano playing movement analysis, more specifically the movements of the arms, fingers position and pressure applied by the pianist. This information is crucial for technique analysis because there was a distinct difference in hand posture and movement strategy of the arm between the professional and amateur pianists [4].

There are three main methods used in finger tracking in piano playing. First method is user-mounted sensors. User-mounted or wearable sensor system had led to many useful applications. The main application of this sensor system includes data collection from athletes and clinic patients where the sensors monitor and diagnose the users [5]. Their current capabilities of this sensor system include physiological and biochemical sensing, and also motion sensing [6,7].

Error! Reference source not found. shows a wearable finger position tracking method for piano playing developed by [8]. The sensors are mounted on the hand of pianist instead of on the piano. This similar method is also used in [9] where accelerometers and gyroscope are placed at the hand of the pianist to track the position of the arm and force applied to the piano. Even though user mounted sensors show promising result on obtaining finger position of the pianist, these methods require sensors to be attached to the pianist. Thus they are considered intrusive to the experience of piano playing, which might affect the natural or usual performance of a pianist.

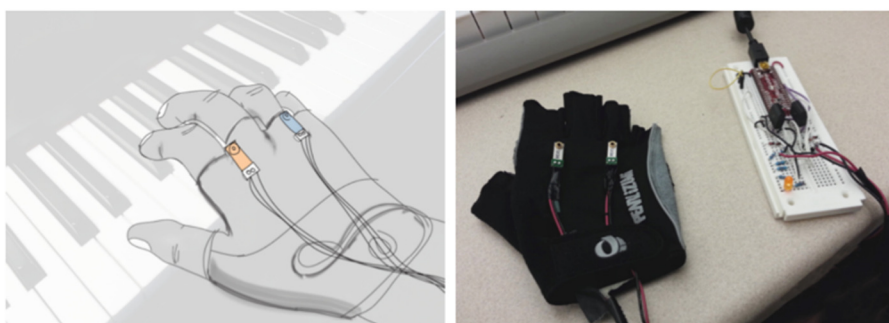

Fig. 1. Glove sensor developed by [8]

The second method is image processing. Studies using motion capture technologies had been carried out with pianists which focus on quantifying the small, quick movements of the wrist, hand, and fingers [10]. The possibility of non-intrusive or unobtrusive motion capture and analysis of characteristics and timing of gestures during musical performances has important implications for researchers interested in quantifying the movement of performers. Mostafizur Rahman et al. employs image processing method to track a pianist's hand motion. However, the challenges for pianists' finger detection is, the pianist fingers are never protruded. In addition to that, they are mostly bend towards the keyboard, which is away from camera, often touching and occluding each other [11]. In another words, optical sensors require a good line of sight on the target to produce reliable results.

The last method is capacitive sensing, one example of capacitive sensing is developed by Tobias et al. A flexible printed circuit board (PCB) is wrapped on the piano key as the electrode for capacitive sensing. The result of the data is shown graphically, providing the data of the position of fingers and the force applied to the key. Despite the ability to track main movement of piano playing, changing the surface of the piano key alters the normal experience of piano playing. Since piano playing consists of very delicate interaction between pianist and the piano, such change of experience may affect a pianist performance.

The current researches show that it is important to track the movement and finger position of the pianist. These data are important for piano pedagogy where teachers could provide accurate

finger positioning data for students. Furthermore, information of virtuoso pianist could be stored accurately so that the details of their piano technique can be preserved. However, challenges arise if these data were to be obtained without intrusive methods, which alter the experience of piano playing. In addition to that, researches on tracking finger position and force applied to the key is underrepresented. Hence, overcoming these challenges become the primary motivation of this research.

The main areas that this paper covered are, firstly, a sensor system is proposed. Next, in-depth discussion on the circuit development of the sensor, which consist of the values of the components used is described. Lastly, the expected outcome of this system is discussed.

2. Methodology

In this research, capacitive sensor is proposed to detect finger position of the pianist because capacitive sensors do not require line of sight for detection, by increasing the range, it could potentially track the fingers remotely without altering the piano playing experience. The maximum distance between the surface of the keys and the bottom of the keyboard of a typical piano is about 13cm as shown in Fig. 2, where the electrode of the sensors is placed under the keyboard area. Since the targeted sensing object, which is the finger will be occurred relatively far away from the sensing electrode, methods which could detect minute capacitance change in the environment should be selected.

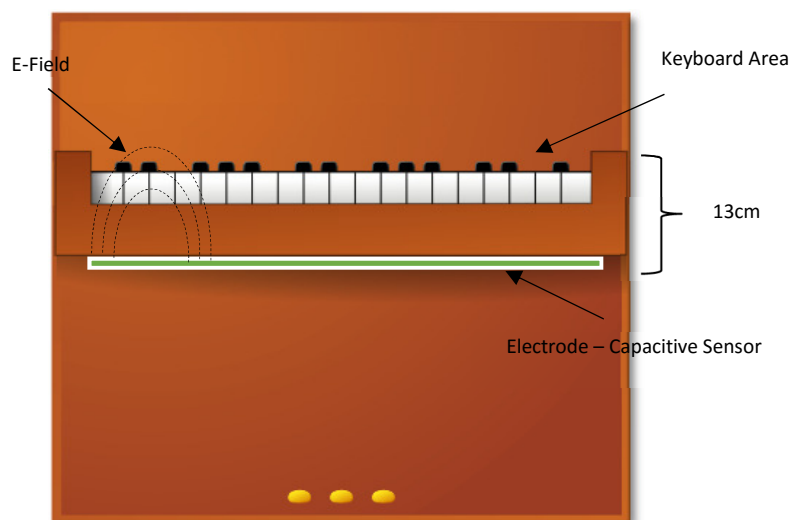

Fig. 2. Electrode mounted right below the keyboard

The choice of a capacitive sensor circuit should consider the required system accuracy, the cost and space available, and the noise environment. In general, there are six types of capacitive sensor circuit [12], the characteristic of each circuit method is describe in

Since the application requires high sensitivity, two circuit methods that are potentially capable of fulfilling the task were proposed in this research, which are charge transfer and RC oscillator. Charge Transfer is one category of capacitive sensing using charge amplification and filtering to measure the sum of all the individual charge contributors around a given sensor. A waveform is generated and converted to a representative capacitance value through a combination of timing filtering means. On the other hand, RC oscillator generates pulses in frequency that depends on the changes of capacitance. Both of these methods are highly sensitive to small capacitance changes, this also means

they are also susceptible to stray and shunt capacitance, as well as noise. This paper aims to compare and select the better method, as well as reducing the noise..

Since the application requires high sensitivity, two circuit methods that are potentially capable of fulfilling the task were proposed in this research, which are charge transfer and RC oscillator. Charge Transfer is one category of capacitive sensing using charge amplification and filtering to measure the sum of all the individual charge contributors around a given sensor. A waveform is generated and converted to a representative capacitance value through a combination of timing filtering means [13]. On the other hand, RC oscillator generates pulses in frequency that depends on the changes of capacitance. Both of these methods are highly sensitive to small capacitance changes, this also means they are also susceptible to stray and shunt capacitance, as well as noise. This paper aims to compare and select the better method, as well as reducing the noise.

Table 1
 Capacitance measurement circuit comparison: 0 is good, 5 is bad

Circuit	Function	Sensitive to stray capacity	Sensitive to noise	Sensitive to shunt resistor	Needs ADC	Size
Charge Transfer	Volt = 1/C	yes	5	5	no	0
RC Oscillator	Freq. = 1/RC Period = RC	yes	5	5	no	1
IC oscillator	Freq. = 1/RC Period = RC	yes	3	5	no	2
LC oscillator	Freq. = $1/\sqrt{LC}$	yes	2	0	no	3
Synchronous Demodulator, Single Ended	Volt = C1- C2	no	1	1	yes	4
Synchronous Demodulator, bridge	Volt = C1- C2	no	0	0	yes	5

3. Electrode and experimental design

The electrode consists of a conductive metal plate. The surface area of the electrode affects the range of sensing significantly as capacitance, C is governed by the equation:

$$C = \epsilon A / d \tag{1}$$

Where ϵ is the dielectric constant of the material between the two conducting plates, A is area of the both conducting plates and d is distance between the two conducting plates. In this application, the dielectric constant, which is the ϵ of the piano keys and air could not be changed. The area of the conducting plate is the only variable that could offset the relatively long distance between the two conducting plate. The surface of electrode must be sufficiently large, yet in the other hand should not exceed the surface area of finger by a large margin. Based on the key size of the typical piano as shown in Fig. 3, electrode of 3 cmx2.5 cm.

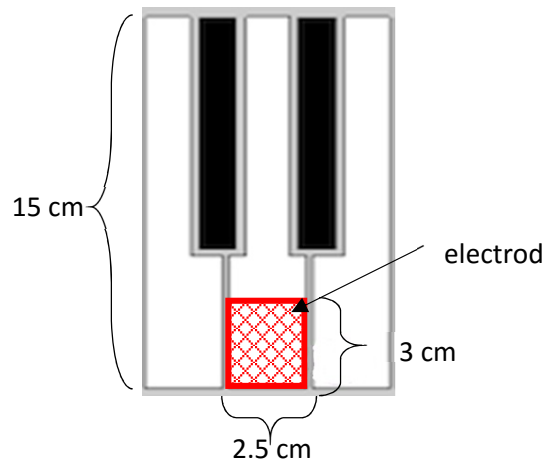

Fig. 3. Keyboard and electrode size

The same electrode will be used by both sensing method, where the electrode is placed under a stack of books. The purpose of the stack of books is to mimic the piano as it conveniently provides a desired distance, and the dielectric constant of paper is close to wood. Both of the sensing methods utilize the same experiment procedure, where the data is first recorded as the user's hand hovers slightly above the books, and then another set of data is recorded after the user's finger pressed on a targeted spot as shown in Fig. 4.

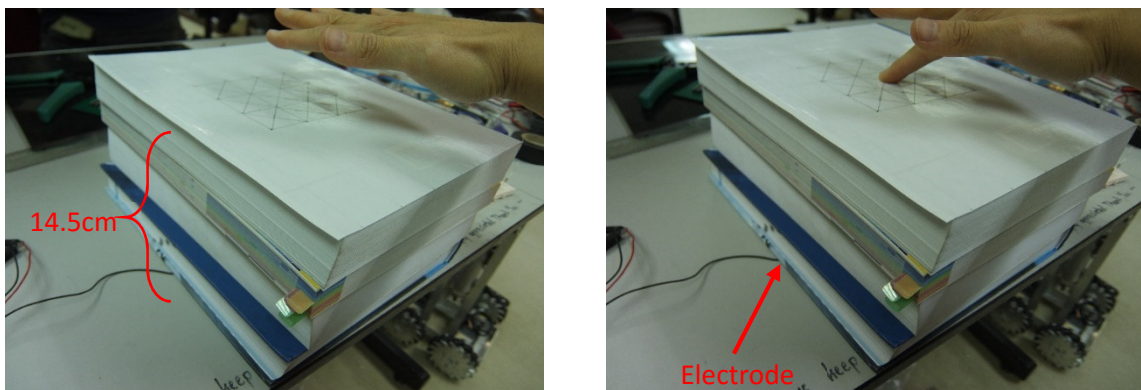

Fig. 4. Experimental design

4. Charge transfer capacitive sensing

Fig. 5 illustrates a brief explanation of the principle of how this method works. A square wave pulse of +5V and -5V is fed to a large resistance. This resistance act as a damper to reduce the charge time for the pulse, this enables user to read the rise time of the pulse with more resolution before it reaches saturation point. The electrode is then connected to the other end of the resistor. When the finger is near to the sensing plate, the capacitance increases and this will take the pulse longer time to reach its saturation period, as a result, it will have a longer rise time. In other words, the change in capacitance on the electrode could be read as the change in rise time of the pulse.

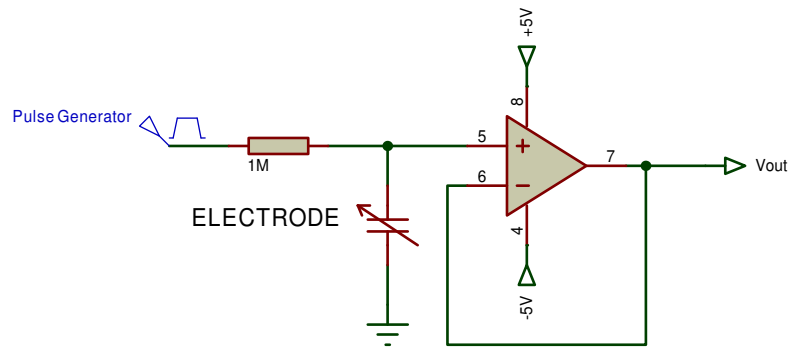

Fig. 5. Charge transfer capacitive sensor

The next stage of the design consists of a Sallen-Key High-pass filter. The cutoff frequency of the filter, $f_c = 97.474285201473\text{Hz}$ and the damping ratio, $\zeta = 0.92479798487465$. The system also provides a fixed gain of 10 as the base amplification of the system. This filter aims to filter out common noises occurred below the cutoff frequency. Since the application requires detection of very small changes of capacitance, another stage of amplification is required, this amplifier circuit provides a maximum amplification of 10 times, together with voltage level shifting so that user could “zoom” and concentrate on the area of interest where the change of rise time occurs. The last stage of the system is the design of an integrator as shown in Fig. , which serve as the detector of the change on the rise time.

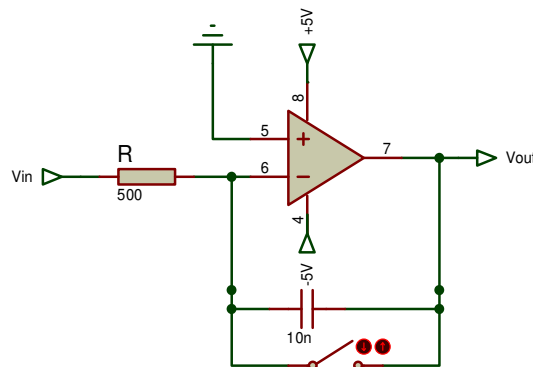

Fig. 6. Integrator

The value of resistance, R is calculated using the standard integrator amplifier equation:

$$V_{out} = - \int_0^t \frac{V_{in}}{RC} dt + C \tag{2}$$

Where worst case scenario is chosen for V_{in} , which is $5V/2 = 2.5V$, V_{out} is the maximum output which is 5V. Capacitance, C is arbitrary set to 10nF and the sampling rate is set to 100kHz. The negative sign in the equation does not concern the overall calculation as the effect is eliminated by the previous stage of negative gain amplification. Therefore, the value R is derived as follow:

$$5V = \frac{1}{R(10nF)} \int_0^{100kHz} 2.5V dt$$

$$50n(R) = \frac{2.5}{100k} \tag{3}$$

$$R = 500\Omega$$

A switch is connected across the capacitor to constantly discharge and reset the reading. V_{out} at this last stage is the final reading of the entire system. The system is first experimented on a breadboard and being developed to a PCB at the final stage as shown in Fig. 7.

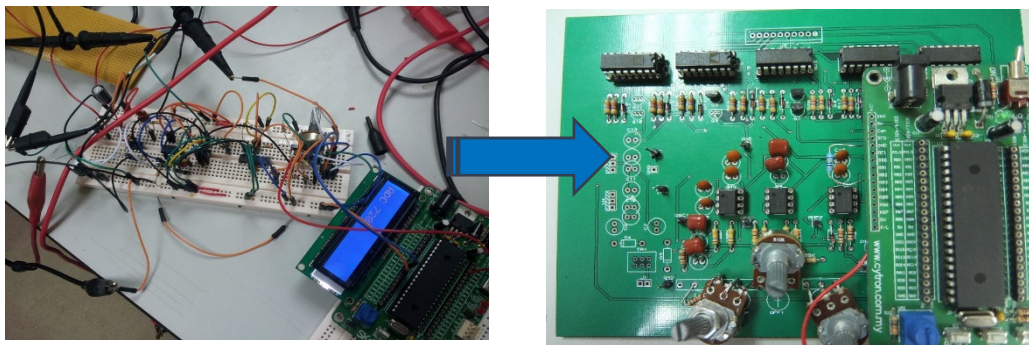

Fig. 7. Development of charge transfer sensing method

5. RC oscillator

Schmitt trigger oscillator is utilized as the RC oscillator for this experiment. One of the main reason Schmitt trigger method is chosen is the pulse could be triggered in low current. Since high frequency oscillator is generally harder to deal with, high value resistance is being selected to lower the frequency, as a result, the resulting current flow is low. By definition, Schmitt trigger is a comparator circuit with hysteresis implemented by applying positive feedback to the noninverting input of a comparator or differential amplifier. It is an active circuit which converts an analogue input signal to a digital output signal. The digital output, which is the frequency of the pulse varies on the changes of the capacitance as shown in Fig. , where C3 simulates the electrode of the system and C2 simulates the stray capacitance generated by the Schmitt trigger integrated circuit.

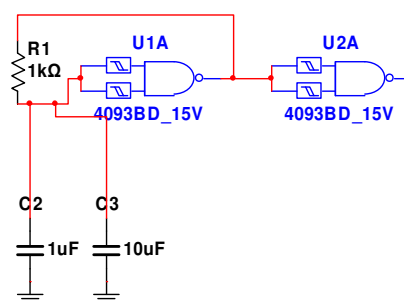

Fig. 8. Schmitt triggered RC oscillator

The schematic of the oscillator is first simulated and the result is shown in Fig. 9. The simulation shows pulses generate by the circuit at a constant frequency. By changing any one of the capacitor, the frequency of the pulses varies accordingly.

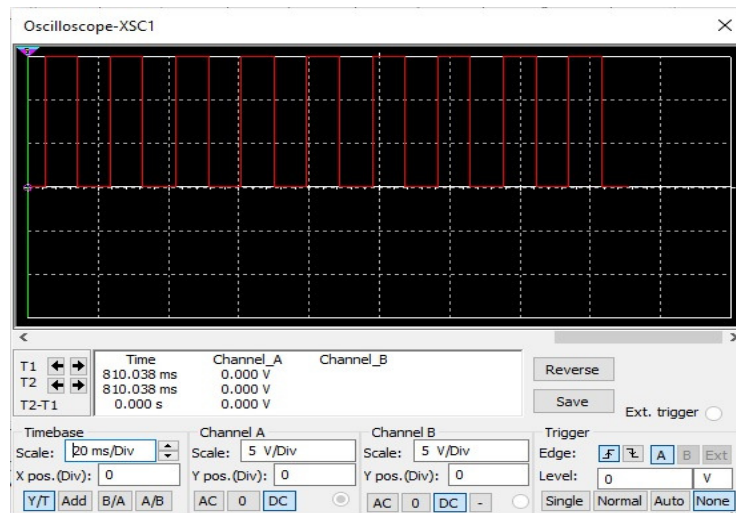

Fig. 9. Circuit Simulation

The schematic is then being developed into a printed circuit board (PCB). The initial state of this sensing method is developed using Paper Pheonolic as the material for the PCB. It is later found out that the high dielectric constant of the material creates high stray capacitance, which greatly hampered the performance of the sensor. The PCB is redeveloped using fibre glass to reduce the stray capacitance. A compensating capacitor is also added to reduce the stray capacitance.

6. Results and discussion

The result of both of the sensing method is read through a digital oscilloscope. Fig. 10 shows the result of the charge transfer sensing method. The first and second frame shows the result before and after the finger pressing the target. The yellow graph shows the post amplified signal whereas blue indicates the output of the sensor without any amplification. One could notice that there is no noticeable change in the blue signal, whereas there is some slight distortion in the yellow signal.

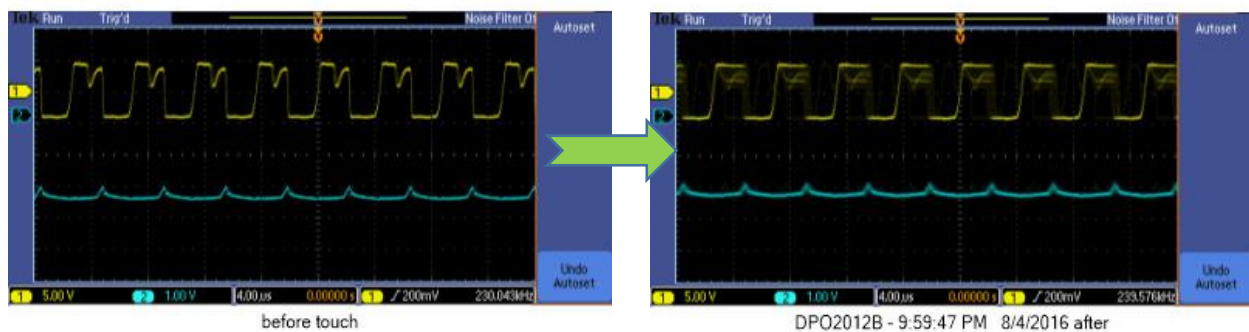

Fig. 10. Charge transfer sensing method

Fig. 11 shows the result of the RC oscillator sensing method. The first and second frame shows the result before and after the finger pressing the target. Before pressing the finger, the pulse oscillates at the frequency of approximately 3 MHz. The second frame shows that the frequency drops to 2.5 Mhz during the finger pressing on the target.

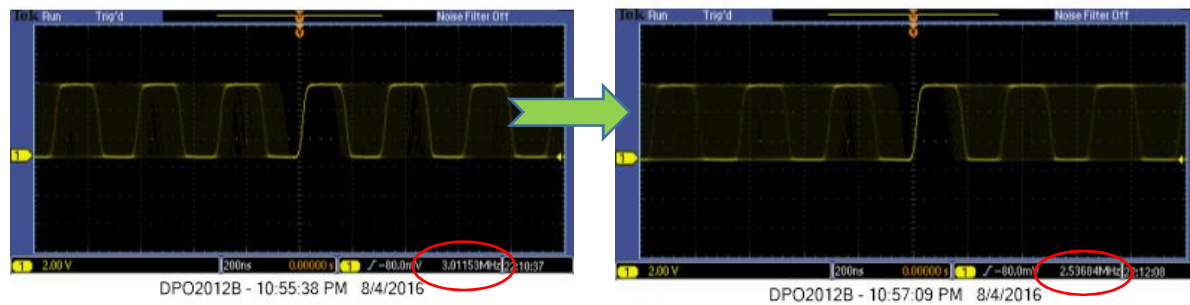

Fig. 11. RC Oscillator Sensing Method

7. Conclusion

In this study, two capacitive sensors method that could potentially detect a remote capacitance change is presented. The RC oscillator method has shown several more favourable traits as the better sensing method in this application. The output of the RC oscillator is easier to process as it is already in digital form whereas one has to compare the waveform change of the charge transfer method in order to decipher the output signal. Furthermore, the size of PCB of RC oscillator is significantly smaller than the charge transfer method.

Acknowledgment

Authors would also like to thank Artificial Intelligent Research Unit (AiRU), Universiti Malaysia Sabah for the funding provided. Authors would also wish to express sincere appreciation to Mr. Tan Tze Tong for his deep insight on piano techniques and pedagogy.

References

- [1] Newton, Dan, and Mark T. Marshall. "Examining How Musicians Create Augmented Musical Instruments." In *NIME*, pp. 155-160. 2011.
- [2] Lähdeoja, Otso, Marcelo M. Wanderley, and Joseph Malloch. "Instrument augmentation using ancillary gestures for subtle sonic effects." *Proc. SMC* (2009): 327-330.
- [3] Grosshauser, Tobias, and Gerhard Tröster. "Finger Position and Pressure Sensing Techniques for String and Keyboard Instruments." In *NIME*, vol. 13, pp. 27-30. 2013.
- [4] Furuya, Shinichi, Tatsushi Goda, Haruhiro Katayose, Hiroyoshi Miwa, and Noriko Nagata. "Distinct inter-joint coordination during fast alternate keystrokes in pianists with superior skill." (2011).
- [5] Patel, Shyamal, Hyung Park, Paolo Bonato, Leighton Chan, and Mary Rodgers. "A review of wearable sensors and systems with application in rehabilitation." *Journal of neuroengineering and rehabilitation* 9, no. 1 (2012): 1.
- [6] Teng, Xiao-Fei, Yuan-Ting Zhang, Carmen CY Poon, and Paolo Bonato. "Wearable medical systems for p-health." *IEEE reviews in Biomedical engineering* 1 (2008): 62-74.
- [7] Bonato, Paolo. "Wearable sensors and systems." *IEEE Engineering in Medicine and Biology Magazine* 29, no. 3 (2010): 25-36.
- [8] Hsiao, Chih-Pin, Richard Li, Xinyan Yan, and Ellen Yi-Luen Do. "Tactile Teacher: Sensing Finger Tapping in Piano Playing." In *Proceedings of the Ninth International Conference on Tangible, Embedded, and Embodied Interaction*, pp. 257-260. ACM, 2015.
- [9] Großhauser, Tobias, B. Tessendorf, G. Tröster, H. Hildebrandt, and V. Candia. "Sensor setup for force and finger position and tilt measurements for pianists." *Proc. SMC* (2012).
- [10] Sugawara, Eisuke. "The study of wrist postures of musicians using the WristSystem (Greenleaf Medical System)." *Work* 13, no. 3 (1999): 217-228.
- [11] Gorodnichy, Dmitry O., and Arjun Yogeswaran. "Detection and tracking of pianist hands and fingers." In *The 3rd Canadian Conference on Computer and Robot Vision (CRV'06)*, pp. 63-63. IEEE, 2006.
- [12] Baxter, Larry K. *Capacitive sensors Design and Applications*. New York: IEEE Press, 1997.