

# Cable Theft Monitoring System (CTMS) Using GSM Modem

S. A. Mohd Chachuli<sup>\*, a</sup>, S. Mohd Nazri<sup>b</sup>, N. Yusop<sup>c</sup> and N. R. Mohamad<sup>d</sup>

Faculty of Electronic and Computer Engineering, Universiti Teknikal Malaysia Melaka,  
Hang Tuah Jaya, 76100 Durian Tunggal, Melaka, Malaysia

<sup>a</sup>sitiமானிய@utem.edu.my, <sup>b</sup>one\_35Z@yahoo.com, <sup>c</sup>norbayah@utem.edu.my, <sup>d</sup>najmiradhi@utem.edu.my

**Abstract** – *This system is developed to help in reducing the number of cable theft activities. Currently, various methods have been applied by many companies to overcome this problem however cable theft activities were still occurred. Thus, a new system based on simple method is proposed in this paper to overcome these problems. The main objective of this project is to design and develop a cable theft monitoring system (CTMS) using GSM Modem. The main parts for this system are Peripheral Interface Controller (PIC) 16F877A microcontroller, voltage divider and temperature sensor. From the experimental results, it showed that CTMS able to detect the voltage drop and temperature changed with 99% of efficiency. This system is expected to enhance the capability of existing system in term of compatibility. With significant improved in range and reliable data accuracy in real time, this project promise a bright future to develop in reducing cable theft activities.*  
**Copyright © 2016 Penerbit Akademia Baru - All rights reserved.**

**Keywords:** GSM, cable theft, temperature sensor, voltage divider.

## 1.0 INTRODUCTION

Nowadays, cable thefts activities have been increased year by year in Malaysia. Total losses incurred by Telekom Malaysia (TM) company were so great and about millions of dollars were expensed in each year. In 2012, RM42 million have been expensed in covering cable cost due to the cable theft in Malaysia [1]. Various methods have been applied by Telekom Malaysia to overcome this problem such as cable theft prevention campaigns at the national level among the community [2], organizing security patrols [1], wiping grease on telecom poles [1], I-Watch (An Anti-Theft Cable Detection and Escalation System) installation [3], and replacement of existing cable to fiber cables [4]. As part of the campaign, TM has begun communicating the community service messages through print media, electronic media (TV and radio), outdoor and online media [2]. For the security purposes, TM is collaborating with PDRM, the local authorities, the other telecommunication company and utilities providers as these are the key stakeholders in mitigating the cable theft issue [2]. TM has obtained cooperation from all parties especially from local community and members of the public in ensuring the communication facilities provided are preserved and protected from any undesired incident such as cable theft, vandalism and any incident which results in interruption of telecommunication services [2].

In order to reduce the number of cable theft cases in Malaysia, the latest technology was developed by Telekom Malaysia (TM) which based on an alarm system. This system is

known as Anti- Theft Cable Detection and Escalation System (I-Watch). I-Watch is a system that alerts telecom's operatives when the thieves attempt to cut a cable, and it also will inform the security guard/operator the location of the incident is happened [1]. However, this system need high cost to be developed and only selected recipients will received the notification messages.

In other countries, Yuanyuan *et al.* introduced anti-theft monitoring method based on tracking resonance frequency and it also able to detect the location of cable theft. Adjustable capacitance, CN and adjustable inductance, LN are connected in parallel and then connected in series with the simplified circuit of street lamp. By injecting a signal with variable frequency into the monitoring circuit, phase difference between the signal voltage (U) and the signal current ( $I_{in}$ ) can be measured. When the phase difference is zero (that is resonance), this signal frequency will be used as resonance frequency of the system [6]. Xiangjun *et al.* proposed capacitance current resonance measurement principle. The capacitance of the cable and the load can be calculated through the resonance measurement method, thus the length of the cable can be calculated. The location of the breaking line can be detected, however this system unable to identify whether the cable is stolen or not [7]. Zen and Yu analyzed the principles and advantages of the current cable guard alarm technology. The mechanism use fuzzy logic to judge the quality of the current, and calculate the protected setting value. It gives out the reliable alarm signal through the electric current dynamic analyses when the cable is cut off and stolen [8].

The aim of this project is to design and develop a system that able to help user in monitoring the cable theft activity with a user friendly security system. Thus, a simple system based on voltage divider method and connected with GSM system will be developed in this paper. Next section will discuss on the topology and architecture of cable theft monitoring system (CTMS), experimental results and analysis of experimental data.

## 2.0 METHODOLOGY

Figure 1 shows the methodology flow of CTMS system. The main parts for this system are Peripheral Interface Controller (PIC) 16F877A microcontroller, voltage divider and temperature sensor. This project can be divided into two parts which are hardware development and software development. Circuit simulation has been done by using Proteus 7 software. Intelligent Schematic Input System (ISIS), Professional software is used to construct the schematic of PIC 16F877A microcontroller and Advanced Routing & Editing Software (ARES) is used to develop the printed circuit board (PCB) layout. PIC 16F877A microcontroller used in this project due to it has 40 pins DIP pinout and it has many internal peripherals. The hardware parts consist of temperature sensor circuit and the output system. Output system is consists of buzzer, alarm light, liquid crystal display (LCD) and Global System Monitoring (GSM) Module. C language is used to execute the program in PIC which it received the signal from the sensors and display the status on LCD display. PIC C compiler is used to assemble the C programming file into HEX file. GSM modem is used to send the messages to the selected recipient regarding to the status and location of cable theft activities.

Two tests were applied to the CTMS prototype which is voltage drop test and temperature changes test. The overall performances were analyzed based on the random test on cable cut and temperature changes. Figure 2 shows the overview of CTMS proposed system. This project is designed based on detection of cable cut on two roads. The roads are labelled as Jalan Bendahara-Jalan Teluk Piah Kanan and Jalan Tengah Masjid-Jalan Tebuk Sri Makmur.

These roads will be connected directly to the microcontroller. If the voltage drop is detected below 85% from the cable voltage, the microcontroller will send the signal to the LCD display, buzzer, warning light and GSM. The temperature sensor also will send the signal to the microcontroller if the temperature is detected more than 40°C. Expected results of voltage drop and temperature changes from CTMS system are described in Table 1 and Table 2.

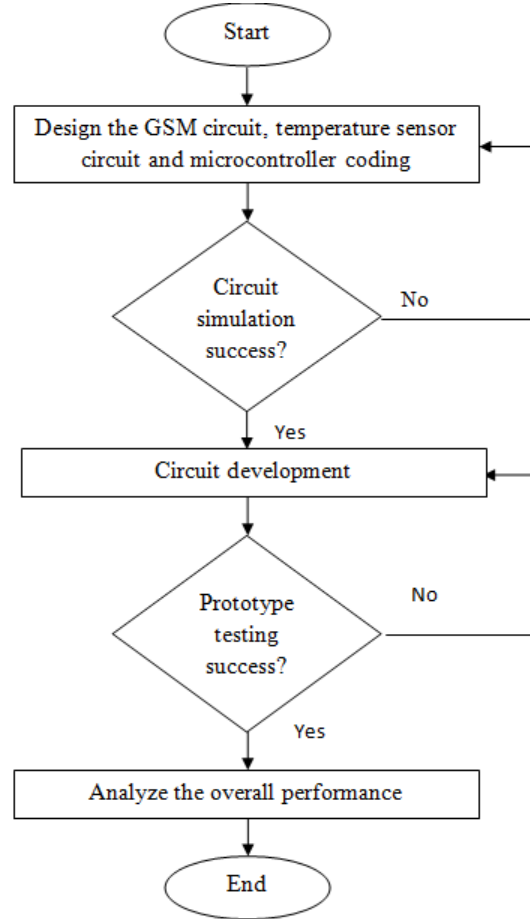

**Figure 1:** Project flow chart

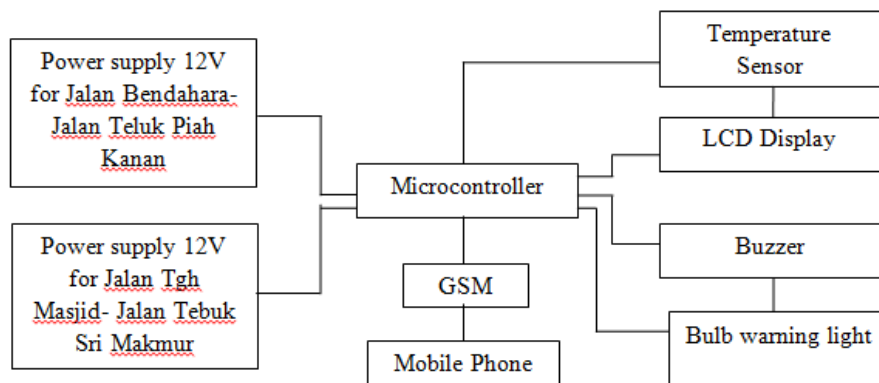

**Figure 2:** Overview of the project

**Table 1:** Expected results for voltage drop

Condition		Voltage Drop ( Less than 10.5 V)			Normal Condition (10.6 - 12V)		
Road							
Jalan Bendahara- Jalan Teluk Piah Kanan		Buzzer ON	Light ON	GSM active	Buzzer OFF	Light OFF	GSM deactivate
Jalan Tgh Masjid- Tebuk Makmur	Jalan Sri	Buzzer ON	Light ON	GSM active	Buzzer OFF	Light OFF	GSM deactivate

**Table 2:** Expected results for temperature changes

Condition		Temperature Change ( More than 40°C )			Normal Condition ( 21°C - 40°C )		
Road							
Jalan Bendahara- Jalan Teluk Piah Kanan		Buzzer ON	Light ON	GSM active	Buzzer OFF	Light OFF	GSM deactivate
Jalan Tgh Masjid- Jalan Tebuk Sri Makmur		Buzzer ON	Light ON	GSM active	Buzzer OFF	Light OFF	GSM deactivate

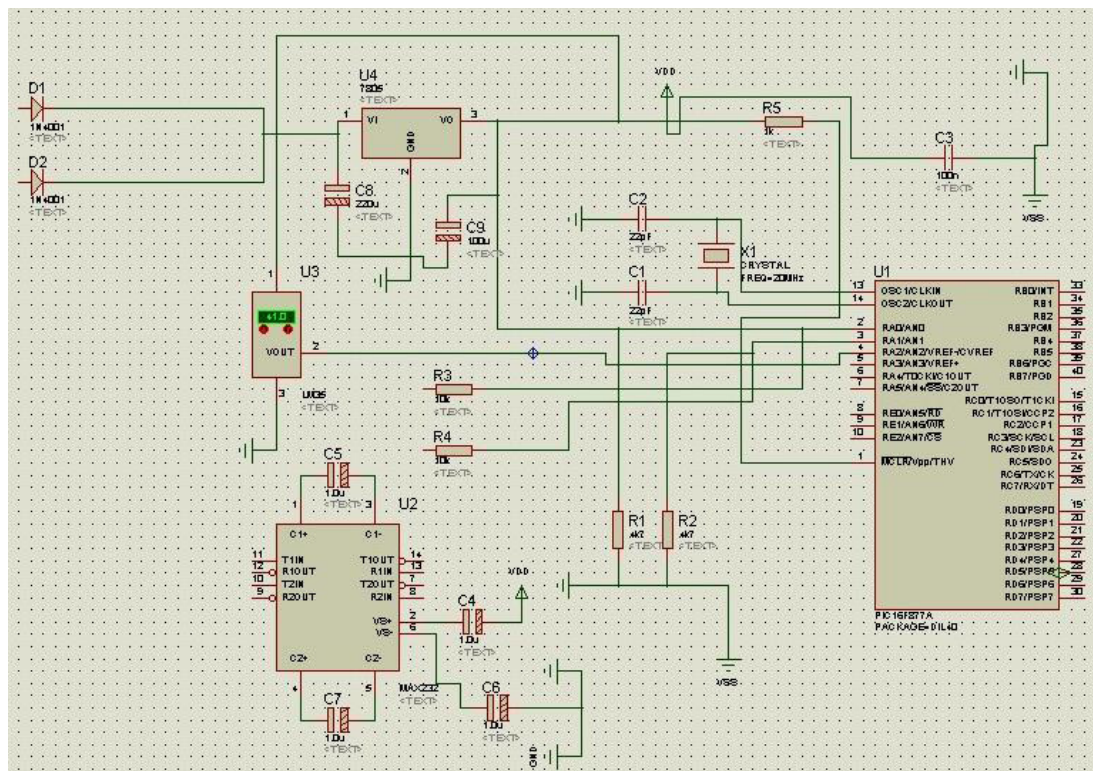

**Figure 3:** Circuit Construction in ISIS with PIC 16F877A Microcontroller

Circuit was constructed using Proteus Software is shown in Figure 3. Two different values of supply voltages have been used in this system. First voltage is 12V; used for alarm system. Second is 5V; used for PIC 16F877A Microcontroller, where the input voltage must be around 4.5 to 5.5V. +5V can be determined by using LM7805 implementing +12V as input. Figure 4 shows a prototype of CTMS system. After prototype is developed, three experimental cases will be tested in this project which is voltage drop, temperature changes and random test on voltage drop and temperature changes.

### 3.0 RESULTS AND DISCUSSION

Three cases have been analyzed in this project to ensure the expected result as shown in Table 1 and Table 2 produced the same results in experimental cases. The analyses have been carried out based on voltage drop, temperature changes and random test on voltage drop and temperature changes.

**Case 1: Voltage Drop.** Voltage drop is defined as the amount of voltage loss that occurs through all or part of a circuit due to impedance. A voltage drop occurs across a component that reduces the electrical potential of the electrons as they pass through it [9]. Voltage drop is tested in this project due to the voltage of the cable will be affected during the cable cutting. Figure 5(a) shows the construction of voltage drop test. The cable is supply with 12V power supply to the controller circuit system. At first, the LCD display at the circuit will show the percentage of the current voltage which is 100% as shown in Figure 5(b). When one or both of cable along the road is cut, the voltage in the cable will drop and the LCD display will show the percentage of current voltage drop immediately as shown in Figure 5(c). Supply voltage that less than 85% from main supply voltage will activate the PIC 16F877A microcontroller. The microcontroller will send the signal to the buzzer, warning light and the GSM module will send the alarm message to the user. 85% voltage drop is chosen in this system due to this voltage value can give early notification to the user when the cable is cut or voltage drop is occurred at the location. If the voltage is increase again to 85% and above (normal), the microcontroller will deactivate the buzzer and warning light, and then GSM module will send the notification of normal condition message to the user. Figure 5(d) and 5(e) show the notification message received by the user when the cable is cut and after the cable is in normal condition.



**Figure 4:** A prototype of CTMS system

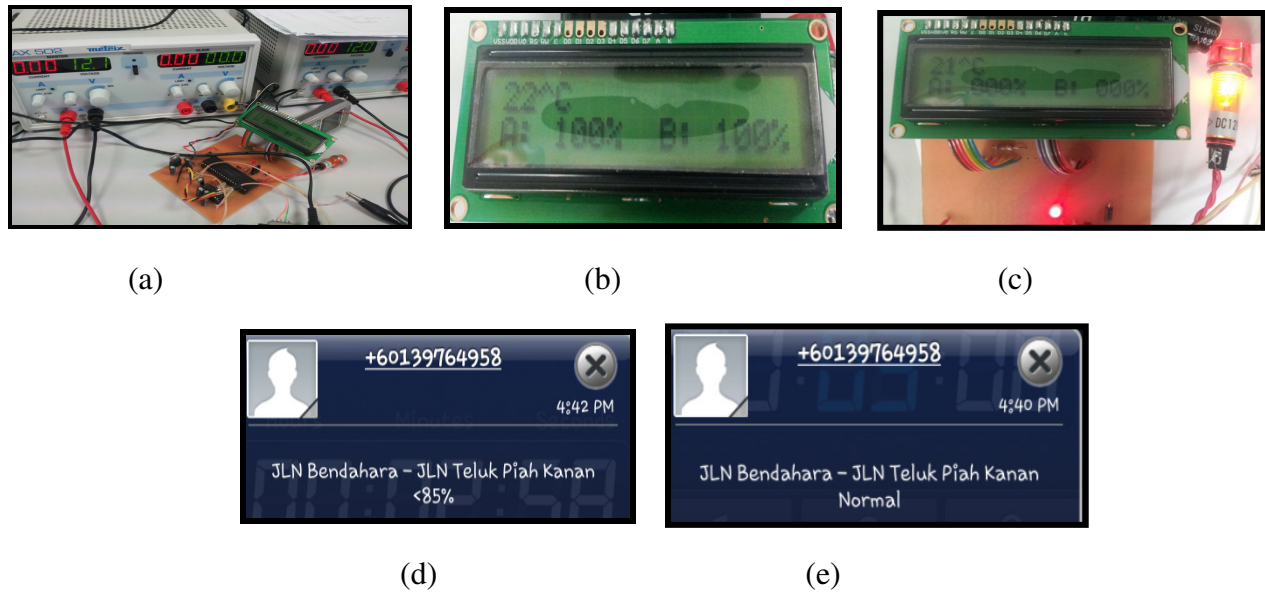

**Figure 5:** (a) The connection for the circuit with 12V power supply (b) 100% display at LCD screen (Normal Condition) (c) 0% displays at LCD screen (Alarm Condition) (d) Alarm message when less than 85% (e) The message when in normal condition.

**Table 3:** The Performance of Voltage Drop Test

Jalan Bendahara-Jalan Teluk Piah Kanan			Jalan Tengah Masjid- Jalan Tebuk Sri Makmur		
Power Supply	Percentages	Alarm Condition	Power Supply	Percentages	Alarm Condition
13 V	100%	Alarm Off (Normal)	13V	100%	Alarm Off (Normal)
12 V	92%	Alarm Off (Normal)	12 V	92%	Alarm Off (Normal)
11 V	85%	Alarm Off (Normal)	10.4 V	80%	Alarm Off (Normal)
10.9 V	84%	Alarm On	10.3 V	79%	Alarm On
10 V	77%	Alarm On	10 V	77%	Alarm On
9 V	69%	Alarm On	9 V	69%	Alarm On
8 V	61%	Alarm On	8 V	62%	Alarm On
7 V	54%	Alarm On	7 V	54%	Alarm On
6 V	46%	Alarm On	6 V	46%	Alarm On
5 V	39%	Alarm On	5 V	38%	Alarm On
4 V	30%	Alarm On	4 V	31%	Alarm On
3 V	23%	Alarm On	3 V	22%	Alarm On
2 V	15%	Alarm On	2 V	15%	Alarm On
1 V	8%	Alarm On	1 V	7%	Alarm On
0 V	0%	Alarm On	0 V	0%	Alarm On

Table 3 shows the performance of voltage drop test. At first, the supply voltage is set to 13V and next, it will be decreased by 1V. From the experimental results, it showed that this system able to work effectively for both roads and the produced results are similar to the expected results shown in Table 1.

**Case 2: Temperature Changes.** Temperature changes are the changes of temperature value either increased or decreased from the normal value of temperature. In this project, the temperature sensor will sense the temperature in range between 21°C until 40°C in the circuit. Normally, the electronic circuit is difficult to overheat because usually the circuit is installed in an air-conditioned room and this circuit also is constructed with heat sink. However, overheat also able to occur if the air space around the circuit is covered with dust or the circuit is not in services for a long time.

In this test, the temperature changes are tested by supplying the heat to the circuit by using lighter. The construction circuit of temperature test is shown in Figure 6(a). If the temperature is detected more than 40°C, CTMS will send the notification message to the user and after the temperature is in normal condition, it also will send the notification message again to the user. The notification messages from this test are shown in Figure 6(b) and 6(c). Table 4 shows the performance of CTMS when temperature sensor is tested. The produced results showed that the alarm is function effectively when the temperature is more than 40°C.

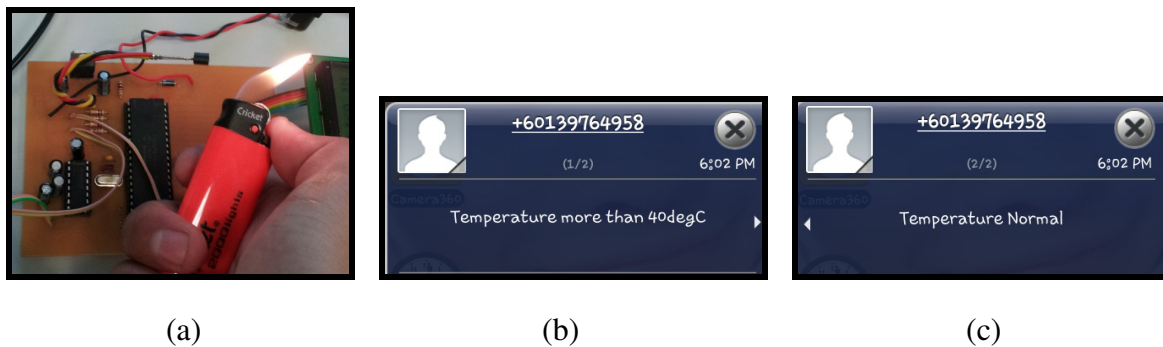

**Figure 6:** (a) The method to make the temperature sensor activate the PIC 16F877A microcontroller (b) Alarm message when the temperature more than 40°C (c) The messages that show the temperature is in normal condition

**Case 3: Random Test on Voltage Drop and Temperature Changes.** Table 5 and Table 6 show the performance of CTMS prototype when random tests have been carried out. The experimental results for the project are compared by percentages of successful with the expected results. From the analyses that have been done, it showed that the percentages of voltage drop are 99% successful and percentages of temperature changes are 99.99% successful. These analyses showed that CTMS prototype able to detect cable cut with 99% efficiency.

**Table 4:** The performance of temperature changes test

<b>Changes Of Temperature Value ( °C)</b>	<b>Alarm Condition</b>
21°C	Off (Normal)
22°C	Off (Normal)
23°C	Off (Normal)
24°C	Off (Normal)
25°C	Off (Normal)
26°C	Off (Normal)
27°C	Off (Normal)
28°C	Off (Normal)
29°C	Off (Normal)
30°C	Off (Normal)
31°C	Off (Normal)
32°C	Off (Normal)
33°C	Off (Normal)
34°C	Off (Normal)
35°C	Off (Normal)
36°C	Off (Normal)
37°C	Off (Normal)
38°C	Off (Normal)
39°C	Off (Normal)
40°C	Off (Normal)
41°C	On
42°C	On
43°C	On

**Table 5:** Performance of voltage drop on random test

<b>Power Supply</b>	<b>Experimental Results</b>	<b>Expected Results</b>	<b>Alarm Condition</b>	<b>Percentages</b>
11.3 V	86 %	86%	Alarm Off (Normal)	100%
10.3 V	79 %	78 %	Alarm On	99%
8 V	61 %	62 %	Alarm On	99%
5 V	39 %	38 %	Alarm On	99%
2 V	15 %	15 %	Alarm On	100%



**Table 6:** Performance of temperature changes on random test

<b>Changes of Temperature Value ( °C)</b>	<b>Experimental Results</b>	<b>Expected Results</b>	<b>Percentages</b>
27 °C	Alarm Off (Normal)	Alarm Off (Normal)	100%
35 °C	Alarm Off (Normal)	Alarm Off (Normal)	100%
41 °C	Alarm On	Alarm On	100%
43 °C	Alarm On	Alarm On	100%

#### 4.0 CONCLUSION

The main objective of this project is successfully achieved where cable theft monitoring system using GSM modem have been successfully designed and developed. This project able to detect the voltage drop on the cable, changes of temperature in the circuit and sends the notification message to the user. The microcontroller also able to activate the buzzer and give warning light, thus it indicates that the cable theft is occurred. The location of cable theft based on two roads can be identified by checking the notification message. Analyses of overall performance of CTMS showed that this system able to work with 99% efficiency. Thus, it can be concluded that this CTMS system is working successfully when cable is cut and under high temperature. This system also offers portability and flexibility to the user.

#### ACKNOWLEDGMENT

The author would like to thank Universiti Teknikal Malaysia Melaka, Malaysia (UTeM) for funding and provide facilities to this project.

#### REFERENCES

- [1] S.I. Lee, (2012). Improved security sees a reduction in cable theft cases. Retrieved on 23th July 2013.
- [2] Kugan (2012). TM cable theft prevention campaign. Retrieved on 15th August 2013.
- [3] Bernama (2012). TM gunasistem I-Watch kesansertamertakecuriankabel. Retrieved on 15th August 2013.
- [4] J. Erma Yusnida, (2013). TM bendungkecuriankabel. Retrieved on 19th August 2013.
- [5] Telekom Malaysia Kuala Selangor (2013). Report from Kuala Selangor monthly cable theft.
- [6] Yuanyuan, Wang, Jian Jinbao, Zeng Xiangjun, and Liu Sidong. "Anti-theft monitoring and location system for cable of street lamp." In Electric Utility Deregulation and Restructuring and Power Technologies (DRPT), 2011 4th International Conference on, pp. 913-915. IEEE, 2011.

- [7] Xiangjun, Zeng, Jin Guangming, Jin Wangyi, and Xu Yao. "Anti theft and monitoring system of street lamp power cables." In Power and Energy Engineering Conference, 2009. APPEEC 2009. Asia-Pacific, pp. 1-4. IEEE, 2009.
- [8] Yu, Zhen. "Study on a new cable guard alarm system based on fuzzy state estimation." In Computer Science & Education, 2009. ICCSE'09. 4th International Conference on, pp. 1867-1872. IEEE, 2009.
- [9] Rashid, Muhammad Harunur. Power electronics: circuits, devices, and applications. Pearson Education India, 2003.