

## Modelling and Virtual Manufacturing of a Flange Tube Using CAD/CAM Tools

Open  
Access

Musa Alhaji Ibrahim<sup>1,\*</sup>, Auwalu Yusuf Gidado<sup>1</sup>, Abdulrahman Shuaibu Ahmad<sup>1</sup>, Saidu Bello Abubakar<sup>1</sup>, Huang Kai<sup>2</sup>

<sup>1</sup> Department of Mechanical Engineering, Faculty of Engineering, Kano University of Science and Technology, Wudil, Nigeria

<sup>2</sup> School of Mechanical Engineering and Automation, Liaoning University of Technology, Jinzhou, PR China

### ARTICLE INFO

#### Article history:

Received 22 August 2017

Received in revised form 11 January 2018

Accepted 4 March 2018

Available online 24 March 2018

### ABSTRACT

Virtual manufacturing, as an advanced machining technology, has been regarded as a useful tool to carry out analysis and research work with digital model instead of practical manufacture. In virtual manufacturing, there is no real production and neither material nor power is wasted. Modelling, mould design, assembly and virtual manufacture of a flange tube has been carried out through the application of such automation technology as CAD/CAM. A CAD tool, Pro/Engineer Wildfire 4.0 software package was used in the modelling of a flange tube as well as in the design and assembly of the mould for the created part. These were achieved based on the dimensions and specifications of both the blank and the finished drawings. The 3D solid model was imported in IGES format from the Pro/Engineer into a CAM tool, MasterCAM4.0 for the virtual manufacture of the flange tube through NC machining simulation of the wax pattern injection mould cavity. The results showed that the part can be modelled and manufactured virtually using CAD/CAM tools and this reduces cost of real prototype, increases performance, improve on product quality and shortens production development cycle.

#### Keywords:

CAD/CAM, modelling, pro/engineer, virtual manufacturing, NC machining

Copyright © 2018 PENERBIT AKADEMIA BARU - All rights reserved

## 1. Introduction

Virtual manufacturing is a non-traditional machining technology which is applied in the manufacture, analysis and synthesis of actual machining from which designers and engineers can have full digital model. It is a mapping of workable machining in computer virtual environment whereby results are obtained in full digital production [1]. This means that there is no real production and neither material nor power is wasted. Virtual manufacturing which is based upon virtual reality has been applied widely in practice. Virtual reality is a procedure or strategy by which products designers and engineers visualize and control with computers mind boggling information which can be used to streamline production of products [2]. It is essentially a computer-based technology that gives designers and engineers a viable, three dimensional and interactive

\* Corresponding author.

E-mail address: [abbanfati2014@gmail.com](mailto:abbanfati2014@gmail.com) (Musa Alhaji Ibrahim)

experiences. Designers and engineers using virtual reality can even interact with a computer-generated environment, without much technical training [3]. More so, through detection, analysis and appraisal of digital production created by virtual manufacturing, the designers and engineers can identify problems quickly and eliminate them prior to manufacture. Virtual manufacturing finds application in aerospace and automotive industries. In the present days, virtual manufacturing based on virtual reality is used in manufacturing industries for creating a simulated environment thereby getting more insight into the manufacture of the product and saving cost and time. Manufacturing industry is particularly well positioned to take advantage of the recent emergence of affordable virtual manufacturing (VM) systems based on standard workstations or PCs [4]. Virtual manufacturing is gradually establishing itself as a high efficiency tool to verify the machinability and practicability of technology for designers and engineers. Virtual manufacturing reduces the cost and the risk of the production exploitation, shorten development cycle and improve the competitive of market [1]. Modelling is an art of abstracting or representing of something real. This may assume many different shapes or forms for example a mathematical model of an economy of a country may consist of set of differential equation or that of an exterior shape of a new car may be sculpted in clay. Engineers develop models throughout product realization process to get answers question. A model is used to evaluate the general appearance and attractiveness of the model as well as structural analysis that may need precise numerical results and demand the use of other model [19].

CAD/CAM technology has achieved a breakthrough in the technical application of computer technologies for manufacturing products thus leading to efficiency, high quality and minimum cost of production [5]. With the increasing development in modern manufacturing, advanced manufacturing processes have greatly impacted upon the manufacturing industries thus proposing higher requirements for the research on and development of CAD/CAM and its application in product design and manufacture especially in the tooling design of processes such as modelling and mould design which require an appreciable number of human-controlled parameters [6]. This therefore, poses many challenges in tooling and process parameters prior to producing acceptable parts [7]. To overcome these challenges CAD/CAM tools such as Pro/Engineer and MasterCAM have been implemented in the manufacturing industries thereby providing diagnosis and solution for many manufacturing problems such as efficiency control and computerized management systems [8] in the production function. Computer Aided Design (CAD) refers to the use of computer technology for the design of objects, real or virtual [9]. Computer-aided design is usually associated with interactive computer graphics, known as CAD system. These systems are powerful tools and are used in the design and geometric modelling of components and products [10]. The design of geometric object shapes, in particular, is often called computer-aided geometric design (CAGD). However, CAD frequently involves more than just shapes, as in the manual drafting of technical and engineering drawings, the output of CAD often must convey symbolic information such as materials, processes, dimensions and tolerances, according to application-specific conventions [11]. On the other hand, Computer-Aided Manufacturing (CAM) involves the use of computer-based software tools that assist engineers and machinists in manufacturing or prototyping product components [12]. CAM may also be referred to as the use of a computer to assist in all operations of a manufacturing plant, including planning, management, transportation and storage, its primary purpose is to create a faster production process and components with more precise dimensions [13,14,15]. Integration of CAD and CAM plays an increasingly important role in modern manufacturing systems and as such the technology has rapidly developed and widely spread in manufacturing industries [16]. The Current major commercial CAD/CAM systems, such as Pro/E, MasterCAM, CATIA, Unigraphics, IDEAS, SOLIDWORKS, CAXA, etc. have many specialized modules

packed together and running on their own proprietary databases. These systems have both CAD and CAM capabilities and the geometric data from CAD can be used in the CAM module with little or no any conversion [17,18,].

This paper is concerned with the modelling and virtual manufacturing of a flange tube using CAD/CAM tools such as Pro/Engineer and MaterCAM software systems.

## 2. Methodology

Although the modelling and mould design of the flange tube production involves many steps, here CAD/CAM tools were applied in the following 3 major steps and these steps are:

- I. 3D modelling of the flange tube
- II. Mold design and Assembly
- III. Mold Cavity NC machining simulation.

### 2.1 3D Modelling of the Flange Tube

Pro/E Wildfire 4.0 features were repeatedly exploited in modelling the flange tube. The Pro/E software base features were used in creating the important geometrical structure of the part. These features were made up of primitive shapes viz.: bend (elbow-like shape) and circular shapes and ellipse that give the part its major geometry and followed by modifiers that facilitated the creations of engineering features such as corners, rounds, chamfers, and other cavities and contour radii of the part. The design variables for the part are circles radii of 194.66 mm, 42.58 mm and for the two ellipse Rx1=49.44 mm, Ry1=59.665 mm and Rx2=98.22 mm and Ry2=113.50 mm and nine holes of radii 18.00 mm and depth 7.40 mm and round dimension of 7.29 mm. Figure 1 and Figure 2 show the as-cast blank and 3-D model of the flange tube respectively.

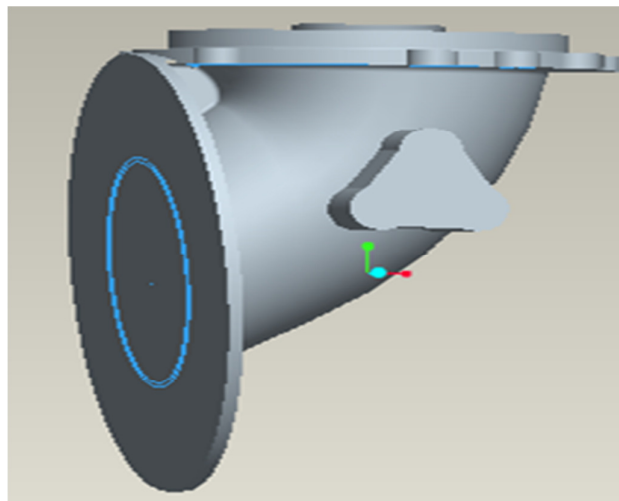
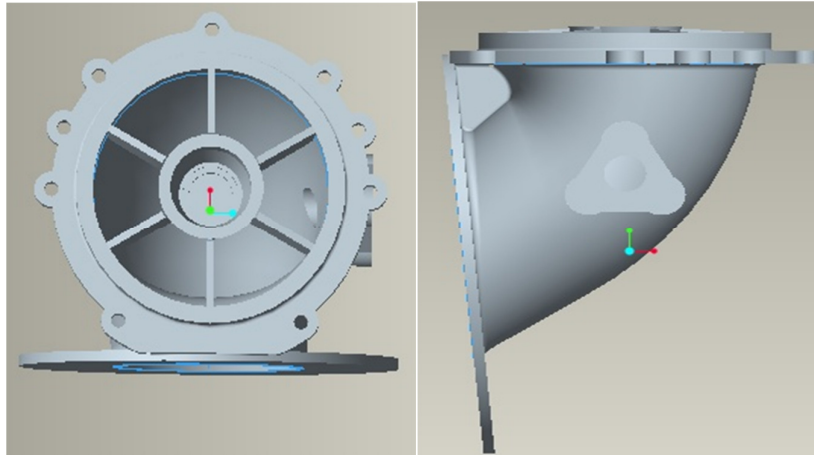
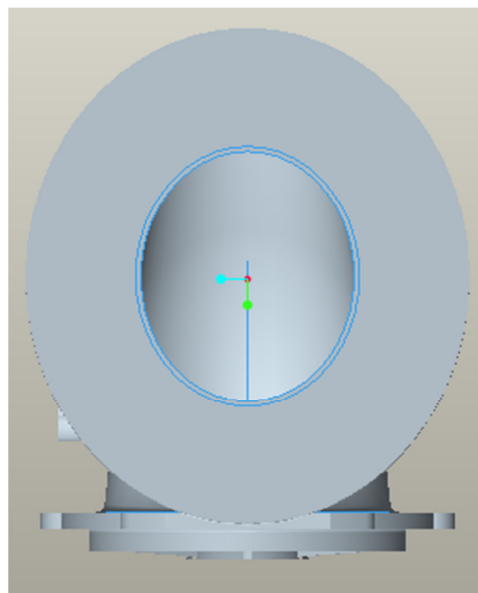

Fig. 1. as-cast blank



**Fig. 2.** 3D model of the flange tube



**Fig. 3.** 3D model of the flange tube

## 2.2 Mould Design and Assembly

The wax pattern injection mould was designed based on the finished drawing specifications. The 3D model of the as-cast blank was created and the mould cavities were created as follows: The model of the part (i.e. the as-cast blank) was imported into the Pro/E assembly module and a 5-workpieces of specified dimensions were created thereby making the bottom and top parts (i.e. lower and upper cavities), the sides part (left and right) and front part of the mould using cut-out method. After considering all the tolerances  $\pm 0.025$ ,  $\pm 0.25$ ,  $\pm 0.3$ , draft angles of  $20^\circ$  and  $25^\circ$ , shrinkage allowance as well as machining processes, the other components such as the sprue, pins, clamping nuts and studs, screws, etc. were separately modelled based on standard sizes and shapes as required for mould assembly and the whole components were assembled using the Pro/Engineer. The figure 3 shows the assembly (unexploded) and exploded views of the mould.

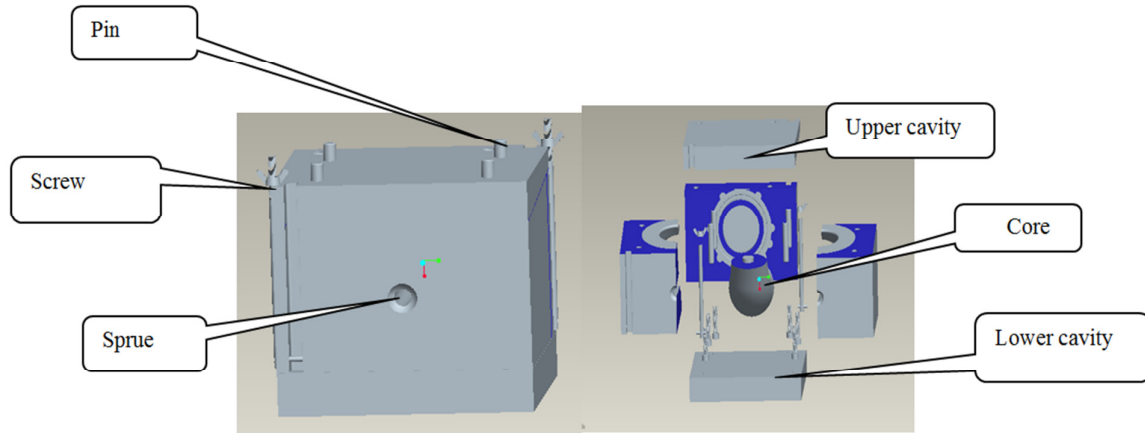

**Fig. 4.** 3D model of the flange tube

### 2.3 Mould Cavity NC Machining Simulation

The machining of mould cavity requires very high accuracy and excellent surface quality [18]. Therefore, it is essential to make use of simulation techniques so as to reach a very high surface quality and surface layer with low stresses and distortions [19] and these techniques could replace the industrial wax which is ideal for producing product prototypes and verifying CNC machining programming [20]. The machining simulation of some parts of the mould cavities from the 3D models all the way to the NC codes generation can be summarized as follows: The 3-D models of the mould upper cavity and side part were saved in IGES file format and imported into the MasterCAM 4.0 manufacturing module. The geometry, toolpath style, type of machine tool, the type of material to use were properly selected. Cutting parameters such as feed, speed and depth of cut were also specified; toolpaths were verified and some adjustments on the cutting parameters were made. The NC codes were generated by post processing the model and then the NC codes customized to accommodate the CNC machine. Figure 4 and Figure 5 show the tool path style and finished operation of some parts of the mould respectively.

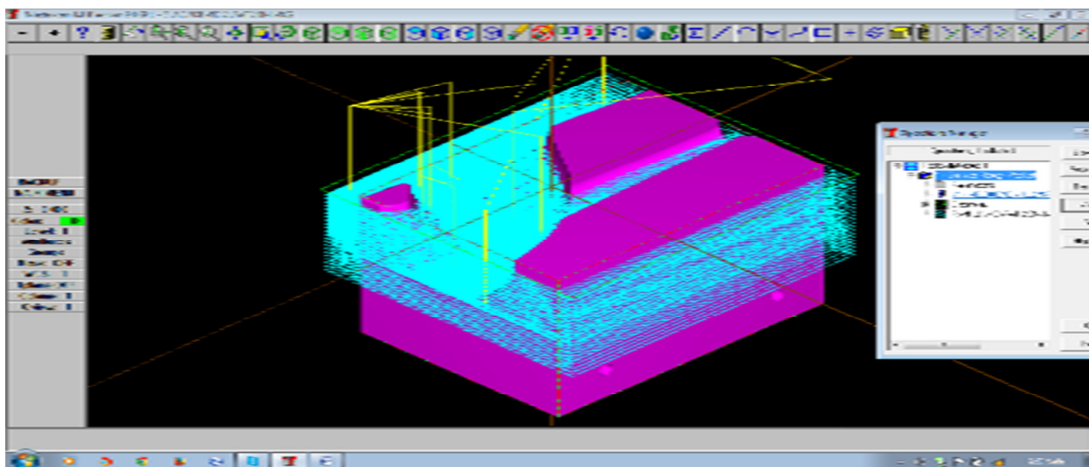

**Fig. 5.** 3D model of the flange tube

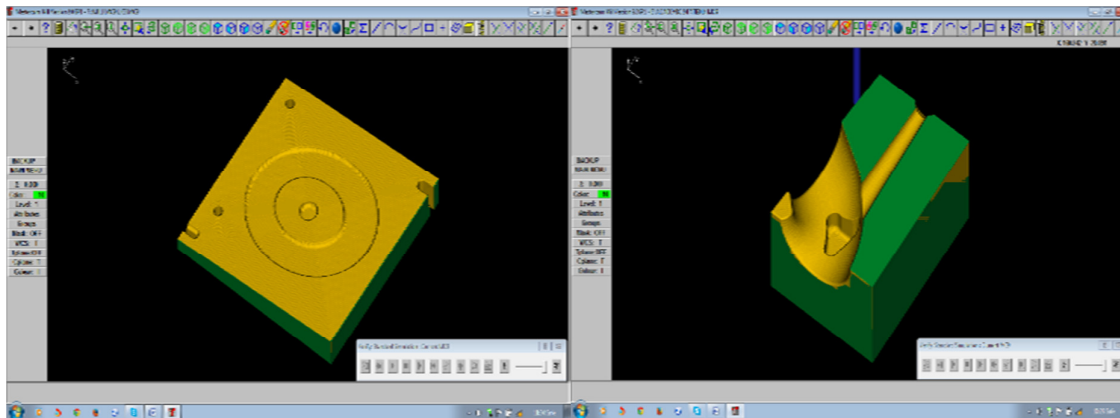

Fig. 6. Finished operation

### 3. Results and Discussion

Virtual manufacturing and modelling have contributed hugely to manufacturing industries in various perspectives. This gives us knowledge on how virtual manufacture could be utilized to cross over any barrier between different offices engaged in the production of products, therefore sparing important time and saving cost. Also, modelling and virtual manufacture assumed an essential part in production planning and prototyping process, though constructing it physically devours additional time and is likewise costly. Virtual manufacturing when combined with simulation tools can reduce design and production cost, as well ensure product quality, and reduce the time required to go from product concept to product realization, while being highly responsive to continually changing and competitive market and world condition.

### 4. Conclusion

The paper has described a simple approach of using CAD/CAM tools in the modelling and virtual manufacturing of a flange tube. Effective utilization of CAD/CAM as automation technology in manufacturing can optimize operations, allow manufacturing flexibility, respond to consumers' requirements and demands, improve product quality, reduce production costs and shorten product development cycle. It can be concluded that CAD/CAM as an automation tool has been applied to modelling and manufacturing of a flange tube virtually without the consumption of materials and power.

### References

- [1] Zhang, Xiao Yan, Yi Xiong, Xiao Jing Li, and Di Wang. "The development of virtual manufacturing technology." In *Applied Mechanics and Materials*, vol. 58, pp. 854-858. Trans Tech Publications, 2011.
- [2] Umar, Zakaria, Abdul Azizz, Faieza, binti Hasan, Rosliza, Abdullah, Muhammad Babayo. "Virtual reality as industrial Training tool for manufacturing technology: A Review". *Journal of Advanced Review on Scientific Research* 31, no.1 (2017): 13-21
- [3] Bowman, Doug A., Joseph L. Gabbard, and Deborah Hix. "A survey of usability evaluation in virtual environments: classification and comparison of methods." *Presence: Teleoperators & Virtual Environments* 11, no. 4 (2002): 404-424.
- [4] Carpenter, I.D., Ritchie, J.M., Dewar, R.G., Simmons, J.E.L. "Virtual Manufacturing." *Manufacturing Engineers, IEEE, UK*, 76, (1997): 113-116.
- [5] Usman, Mustapha M., Abdulrahman S. Ahmad, Nuhu A. Sulaiman, and Musa A. Ibrahim. "Application of CAD/CAM Tools in the Production of Investment Casting Part."
- [6] Ravi, B., and G. L. Datta. "Metal Casting—Back to Future." In *52nd Indian Foundry Congress*. 2004.

- [7] Chwastyk, P, Kolosowk, M. "CAD/CAPP/CAM Integration System in Design Process of Innovative Products". In Proc. Conf. 23rd International Symposium. DAAAM: 2012
- [8] N. Rajae, A. A. S. A Hussaini, A. Zulkharnain and S. M. W Masra. "Bio-inspired Computing for Network Modelling". *Journal of Advanced Research Design* 6, no1. (2015): 1-10
- [9] Ravi, B. "Casting simulation and optimisation: benefits, bottlenecks and best practices." *Indian Foundry Journal* 54, no. 1 (2008): 47.
- [10] Farin, Gerald E., Josef Hoschek, and Myung-Soo Kim, eds. *Handbook of computer aided geometric design*. Elsevier, 2002.
- [11] Mattson, Mike. *CNC programming: principles and applications*. Cengage Learning, 2009.
- [12] Farin, Gerald E. *Curves and surfaces for CAGD: a practical guide*. Morgan Kaufmann, 2002.
- [13] Radhaakrishnan, P, Subramanyan S, Raju, V. CAD/CAM/CIM. New Delhi: New Age International (P) Limited, 2008.
- [14] Kong, Jian and Song, Yanliang. "Analysis on the application of modern manufacturing-Oriented CAD/CAM". *Journal of Theoretical and Applied Information Technology* 50, no.3 (2013): 50.
- [15] Narayan, Lalit K, Mallikarjuna Rao K, Sarcar MM. Computer Aided Design and Manufacturing. New Delhi: Prentice Hall of India Learning Private Limited, 2013.
- [16] Kalpakjian, Serope, Steven R. Schmid, and Hamidon Musa. *Manufacturing engineering and technology: machining*. China Machine Press, 2011.
- [17] Xu, Xun. "Integrating Advanced Computer-Aided Design, Manufacturing, and Numerical Control." *Information Science Reference* (2009).
- [18] Ahmad, Suhairi Bin. "Application of PRO/Engineer in CAD/CAM". Assessed November 10, 2017. <http://www.ptss.edu.my>
- [19] Ping, T. Y. *Advanced Manufacturing Technology*. P.R China: China Press, 2002.
- [20] Pratt, Michael J. "Virtual prototypes and product models in mechanical engineering." In *Virtual Prototyping*, pp. 113-128. Springer, Boston, MA, 1995.