

Semi-active suspension system using MR damper with PSO-skyhook and sensitivity analysis of PID controller

Open
Access

Ahmad Hafizal Mohd Yamin ^{1,*}, Intan Zaurah Mat Darus ¹, Nur Safwati Mohd Nor ¹ and Mat Hussin Ab Talib ¹

¹ Faculty of Mechanical Engineering Universiti Teknologi Malaysia, 81310 Skudai Johor, Malaysia

ARTICLE INFO

Article history:

Received 14 April 2017

Received in revised form 31 May 2017

Accepted 18 June 2017

Available online 19 June 2017

ABSTRACT

This paper introduces the use of Particle Swarm Optimization (PSO) algorithm to tune Skyhook controller & Sensitivity Analysis method to tune PID controller for semi-active suspension system in furtherance of increasing and enhancing the ride comfort and vehicle stability. The performance of skyhook and PID controller are optimized by PSO and Sensitivity Analysis respectively. The mean square error (MSE) of the system is set as an objective function for optimization process of the proposed controller. The performances of proposed controllers are compared with the passive system in terms of sprung displacement & sprung acceleration. The bump & hole and random road profile is set as a disturbance of the system. The simulated results reflect that the proposed controllers offer a significant improvement in ride comfort and vehicle stability.

Keywords:

Semi-active, quarter car, skyhook, PSO, PID, sensitivity analysis

Copyright © 2017 PENERBIT AKADEMIA BARU - All rights reserved

1. Introduction

The comfort ability is one of an important criterion in designing a car suspension system. The purposes of the car suspension are to minimize the car body vibration caused by the road surface, to support the vehicle body together with assuring the comfort ability of the vehicle occupant and for vehicle handling as mentioned by Xiangying [1]. Ride comfort has become one of the important criteria in a passenger vehicle. For a good ride comfort, isolating the passenger compartment from

* Corresponding author.

E-mail address: ahmadhafizal89@gmail.com (Ahmad Hafizal)

the vibration sources is the main idea as highlighted by Rosli *et al.* [2]. Recently, most of researches in vehicle dynamics mostly toward suspension system in order to achieve quality vehicle ride and handling as highlighted by Fischer and Isermann [3]. Then, Fischer and Isermann [3] stated that the suspension system of ground vehicle is located between the vehicle body and the vehicle wheels, and the components of suspension depend upon the type of suspension system. There are three types of vehicle suspension system such passive system, semi-active system and active system. The applied semi active and active suspension systems will normally promises a good stability in terms of vehicle's ride and handling performances. The conventional suspension system which consists of spring and shock absorber or damper as its main element is typically has a limited ride comfort performance. The passenger are normally best isolated from low-frequency disturbances when the damping is high. However, high damping provides poor high frequency absorption. Conversely, when the damping is low, the damper offers sufficient high-frequency absorption, at the expense of low-frequency isolation [4].

2. Semi-Active Quarter Car Model with MR Damper

Semi-active suspension system is almost similar to the conventional suspension system. This type of suspension has a spring and controllable damper in which the spring element is used to store the energy, meanwhile the controllable damper is used to dissipate the energy. Some of the semi-active suspension systems use the passive damper and the controllable spring. The different between semi-active and passive system is damping mechanism system in which the damper system of semi-active can change the damping force in real time depending on the dynamics of the controlled masses as mentioned by Rashid *et al.* [5]. The controllable damper usually acts with limited capability to produce a controlled force when dissipating energy. Figure 1 shows the schematic diagram of semi-active system with passive spring and controllable damper as a component of the suspension. By using Newton's second law, the mathematical equation can be described as follows:

$$m_s \ddot{x}_u + F_d - k_d(x_u - x_s) = 0 \quad (1)$$

$$m_u \ddot{x}_u - F_d + k_s(x_u - x_s) - k_t(x_r - x_u) = 0 \quad (2)$$

where m_s is sprung mass, m_u is unsprung mass, x_r is road profile, x_u is unsprung mass displacement, x_s is sprung mass displacement, k_s is spring stiffness, and F_d is damper force. The parameters of the quarter car model system used in this model are shown in Table 2 based on experimental test rig built in Active Vibration Control Lab, Faculty of Mechanical Engineering UTM. The parameters used based on the ratio 1:4 compared to the original values of quarter car model

Table 1
 Parameter of quarter car model

Parameter	Value
Sprung mass, m_s	80.5 kg
Unsprung mass, m_u	18.5 kg
Damping coefficient, c_s	1500 Ns/m
Spring stiffness, k_s	45409 N/m
Tyre stiffness, k_t	274680 N/m

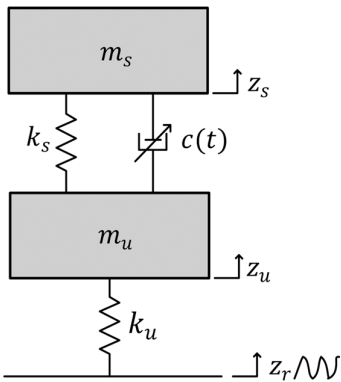

Fig. 1. Semi-active quarter car model

The main issues needs to be highlighted in the use of semi-active MR damper in the vehicle suspension system as shown Figure 2 is how to design a suitable control strategy to overcome damping constraint and to reduce unwanted motion of body vehicle due to pass through road profile disturbance based on existing MR damper model. This is due to the fact that, improper design of control scheme will lead the optimum target force is unpredicted. In addition, a proper design of control strategy is also important in overcoming the damper constraint by providing the same direction between target force and damper velocity. The advantages in the use of MR damper control strategy in improving the vehicle dynamics have been investigated extensively through simulation and experimental studies by many researches [6][7][8]. The block diagram of semi-active suspension system with intelligent controller and MR damper actuator used in this simulation shown as Figure 2.

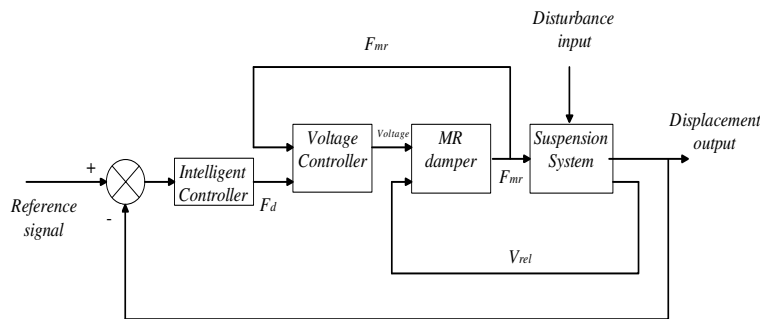

Fig. 2. Block diagram of the Semi-active System

3. Modelling and Control Suspension System

3.1 PSO Skyhook Controller

The skyhook control is a classical control strategy for the vehicle suspension system proposed by Karnopp in 1974 [9]. The Skyhook control system is one of the methods used to eliminate the trade-off between resonance control and high frequency isolation. In order to reduce the resonant peak of the sprung mass significantly and to achieve a good ride quality, the skyhook control is applicable for both a semi-active system as well as an active system [10]. It has been widely used in the control field of semi-active suspension. The ideal damping force can be defined as:

$$F_d = c_{sky} \dot{z}_s \quad (3)$$

where c_{sky} is the coefficient of skyhook damping. The ideal skyhook strategy is hard to be realized in practice, so it is usually used in a form of equivalent model.

The PSO was introduced in early 1995 which are inspired by the behaviour of bird flocking. The swarm represents the number of potential solutions and the individual in PSO called particle which mean each individual in search space can be adjusted dynamically based on the movement of position and velocity as highlighted by Talib and Darus [8]. Control diagram of suspension system using PSO-Skyhook used in this simulation shown in Figure 3.

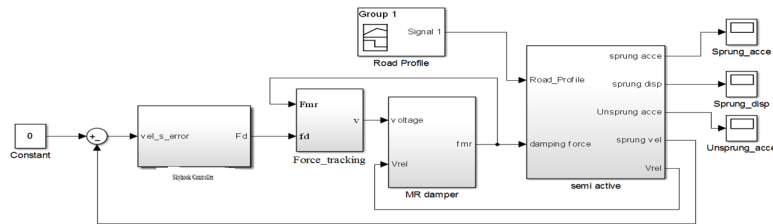

Fig. 3. Control diagram of Semi-active system using Skyhook Controller with PSO

3.2 Sensitivity Analysis of PID Controller

PID is a remarkable control strategy, widely used in processes industries as. PID controller has been proven in terms of reliability and robustness in controlling process variables. There are few factors that attracted industries and research development to choose PID controller such low cost, easy to maintain, simplicity in control structure and easy to understand.

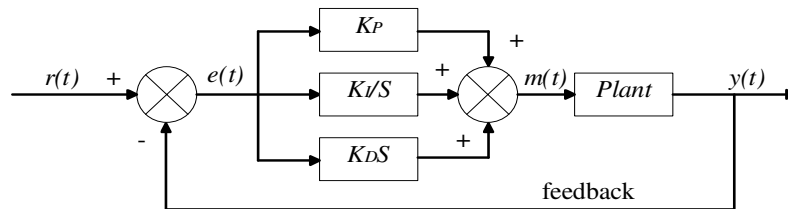

Fig. 4. PID controller block diagram

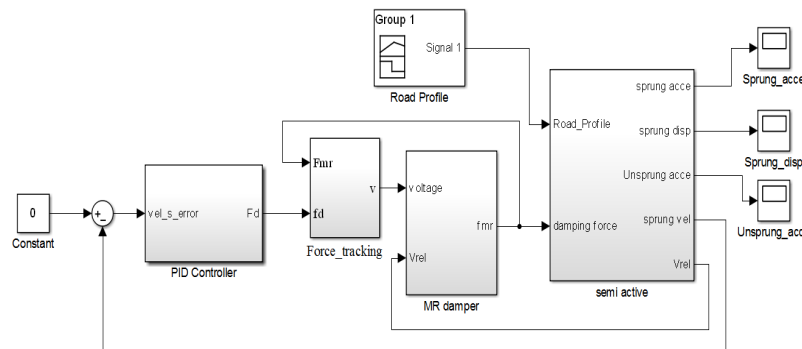

Fig. 5. Control diagram of Semi-active system using PID Controller

PID controller as shown in Figure 4 is designed to control the feedback error of sprung velocity from the system so that the proposed controller can estimate the desired force that can be sent into

the system. Besides, PID Controller is one of the effective feedback control structure in dynamical system as well as most familiar and simple compare to the other controllers [11]. The critical part in designing the PID controller is to obtain the best values of its parameters (k_p , k_i , k_d). Then, Sensitivity analysis or trial and method is used to tune the parameter values of the PID controller. The control diagram of semi-active system using PID control tuned with sensitivity analysis as shown in Figure 5.

4. Result and Discussion

In this simulation, there are two types of disturbance been applied such Bump & Hole and Random input. The values of skyhook damping and PID (k_p , k_i & k_d) used in this simulation are tabulated as per Table 2.

Table 1
 Skyhook Damping & PID Values

Input	System	k_p	k_i	k_d	C_{sky}
Bump & Hole	PSO-Skyhook	-	-	-	7482
	PID Controlled	23	400	88	-
Random	Passive	-	-	-	-
	PSO-Skyhook	-	-	-	6313
	PID Controlled	105	190	91	-
	Passive	-	-	-	-

4.1 Bump and Hole Input

Based on Figures 6 and 7, it is clearly observed that the Skyhook tuned using PSO and self-tune PID manages to reduce the amplitude oscillation better than passive system for body displacement and body acceleration responses. It can be mentioned the force transmitted from the unsprung to sprung masses has been reduced in order to improve the body vehicle.

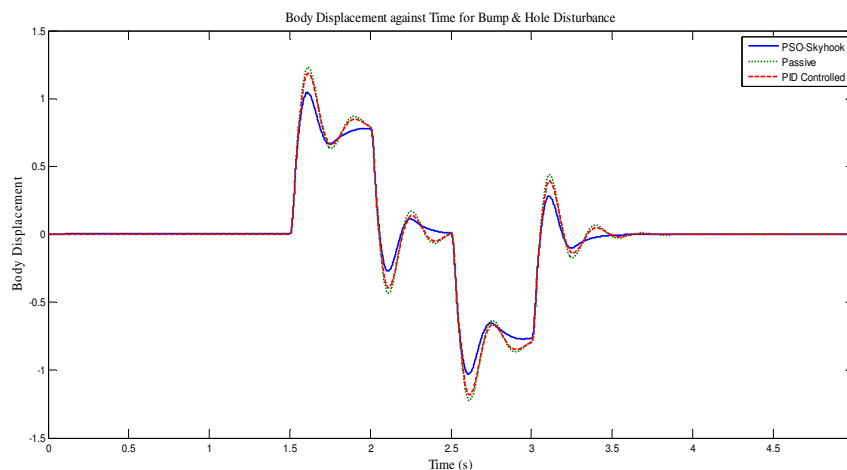

Fig.6. Body Displacement Response for Bump & Hole Input

It is proven during unsprung acceleration response, the performance of the semi-active system using PSO-Skyhook and Sensitivity Analysis of PID controller are slightly worse than the passive system. For comparison of the proposed optimization technique, the skyhook tuned using PSO has shown slightly better than Sensitivity Analysis of PID controller.

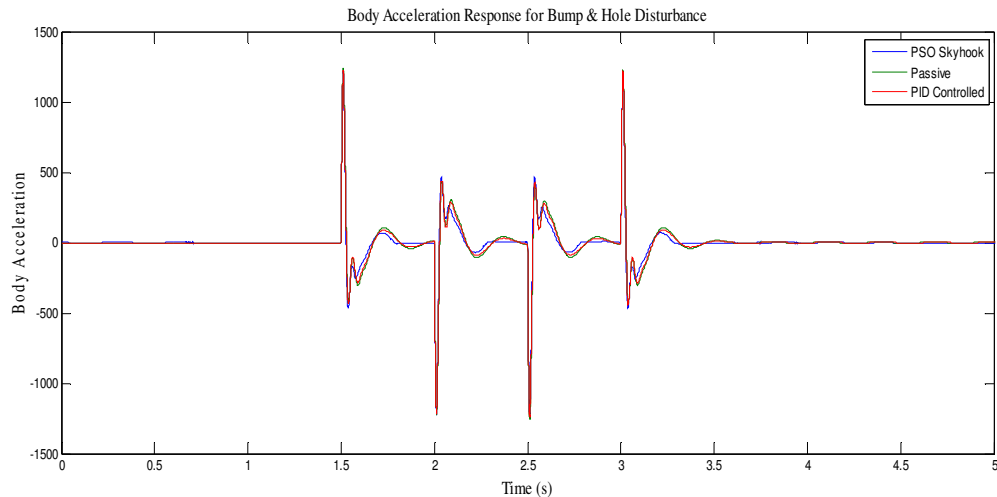

Fig.7. Body Acceleration Response for Bump & Hole Disturbance

4.2 Random Input

It can be mentioned/stated that semi active suspension system managed to control the system better than a passive system as per body displacement response for random disturbance as shown in Figure 8. However, the control system using semi active system does not have a good enough improvement in body acceleration analysis as shown in Figure 9. Hence, passenger and driver's comfort in term of ride and handling might not as better as controller strategy.

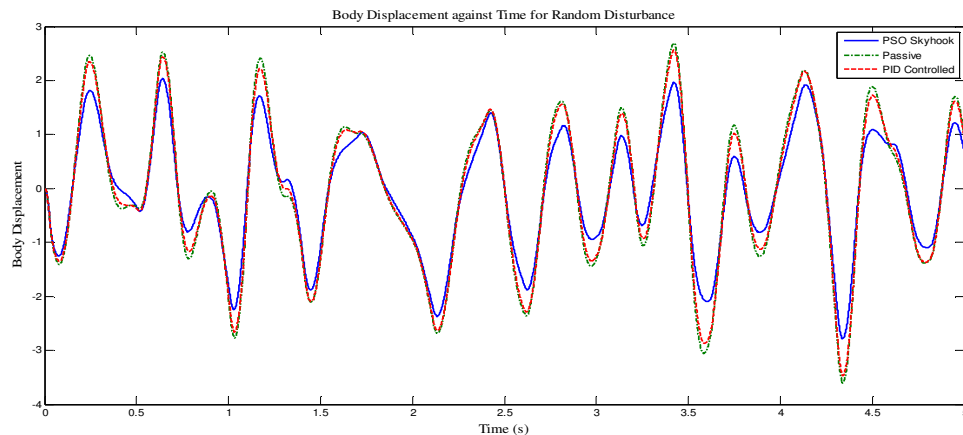

Fig. 1. Body Displacement Response for Random Input

Table 2
 MSE and percentage improvement

Input	MSE		Improvement (%)	
	Bump Hole	Random	Bump Hole	Random
PSO-Skyhook	1.044	2.237	15.12	18.36
PID Controlled	1.187	2.563	3.50	4.82
Passive	1.23	2.693	-	-

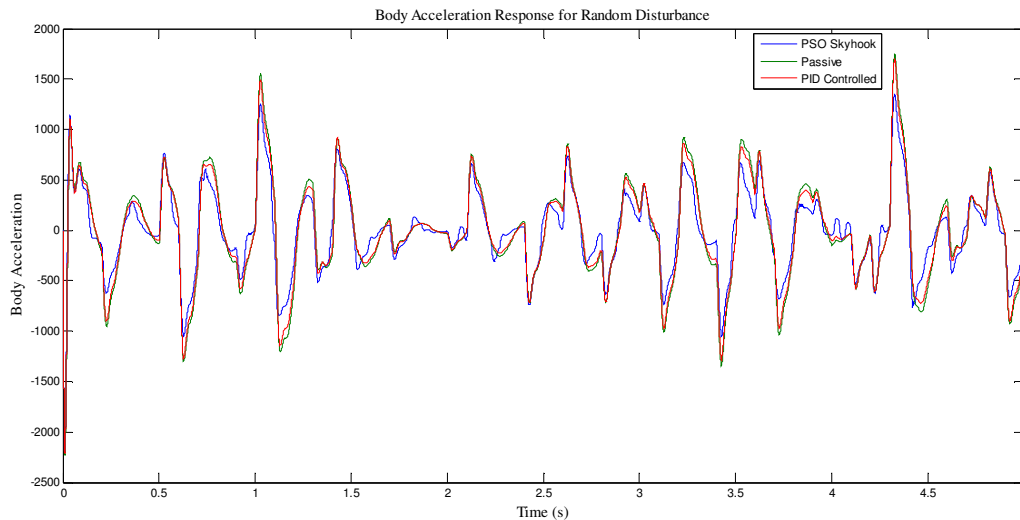

Fig. 2. Body Acceleration Response for Random Disturbance

The result for both body displacement and body acceleration shows improvement when semi-active system with controller been added into the suspension system. Furthermore, the difference of magnitude for measured parameter had shown a slightly higher for semi active system rather than the passive system. The settling time for semi active only requires short periods to stable after applied bump and hole input to the system. Table 3 clearly shows that the semi active suspension system gives the small values of MSE compared to passive system for both bump and hole as well as random inputs. The main purpose of this simulation is to control body displacement for quarter car model and at the same time other output parameters such as body acceleration

4. Conclusion

The Proposed PSO Skyhook and self-tune PID controllers for semi-active system have been developed using MATLAB Simulink. Based on the simulation results shown in Table 2 & 3, the PSO Skyhook system shows a better improvement than the Sensitivity Analysis of PID and passive system, with 15.12% and 18.36%, respectively. It can be concluded that the semi-active system using the proposed controllers are able to improve the vehicle performance as compared to the passive system.

References

- [1] Yiming, Rong, and Bao Xiangying. "An automobile semi-active suspension system using neural network control and simulation." In *Intelligent Mechatronics and Automation, 2004. Proceedings. 2004 International Conference on*, pp. 187-190. IEEE, 2004.
- [2] ROSLI, ROSMAZI, MUSA MAILAH, and GIGIH PRIYANDOKO. "Active Suspension System for Passenger Vehicle using Active Force Control with Iterative Learning Algorithm." *WSEAS Trans. Syst. CONTROL* 9 (2014): 120-129
- [3] Fischer, Daniel, and Rolf Isermann. "Mechatronic semi-active and active vehicle suspensions." *Control engineering practice* 12, no. 11 (2004): 1353-1367.
- [4] Bakar, SA Abu, P. M. Samin, H. Jamaluddin, R. A. Rahman, and S. Sulaiman. "Semi active suspension system performance under random road profile excitations." In *Computer, Communications, and Control Technology (IACCT), 2015 International Conference on*, pp. 93-97. IEEE, 2015.
- [5] Rashid, Muhammad Mahbubur, Nasrudin A. Rahim, Mohammed Azlan Hussain, and M. Azizur Rahman. "Analysis and experimental study of magnetorheological-based damper for semiactive suspension system using fuzzy hybrids." *IEEE Transactions on Industry Applications* 47, no. 2 (2011): 1051-1059.

- [6] Rashid, M. M., M. A. Hussain, N. Abd Rahim, and J. S. Momoh. "Development of a semi-active car suspension control system using magneto-rheological damper model." *International Journal of Mechanical and Materials Engineering* 2, no. 2 (2007): 93-108.
- [7] Nugroho, Pipit Wahyu, Weihua Li, Haiping Du, Gursel Alici, and Jian Yang. "An adaptive neuro fuzzy hybrid control strategy for a semiactive suspension with magneto rheological damper." *Advances in Mechanical Engineering* (2014)
- [8] Ab Talib, Mat Hussin, and Intan Zaurah Mat Darus. "Intelligent fuzzy logic with firefly algorithm and particle swarm optimization for semi-active suspension system using magneto-rheological damper." *Journal of Vibration and Control* 23, no. 3 (2017): 501-514.
- [9] Crosby, M. J., R. A. Harwood, and D. Karnopp. "Vibration control using semi-active force generators." *Journal of engineering for industry* 96, no. 2 (1974): 619-626.
- [10] Priyandoko, Gigih, Musa Mailah, and Hishamuddin Jamaluddin. "Vehicle active suspension system using skyhook adaptive neuro active force control." *Mechanical systems and signal processing* 23, no. 3 (2009): 855-868.
- [11] Vrančić, Damir, Youbin Peng, and Stanko Strmčnik. "A new PID controller tuning method based on multiple integrations." *Control Engineering Practice* 7, no. 5 (1999): 623-633.